

[Push - pull solenoids]

1. Design and Features

The push-pull solenoid design utilizes a coil with the maximum amount of magnet wire in the smallest amount of space. This coil assembly is then packaged in a metal housing using highly permeable steel thus obtaining maximum force and minimum size and weight. The armature design utilizes a secondary magnetic circuit, which provides an increased output of force of 20-50% (comparison is made of a 491C with a stroke of 3 mm). The push design is meant for applications that require relatively short strokes (0-8mm). In general, the solenoid height is half the outside diameter. The output shaft is attached to the armature and can be attached to either end of the solenoid. Thus, attaching to the shaft on the base side actuates as a push solenoid. Attaching to the shaft on the armature side actuates the solenoid in the pull mode.

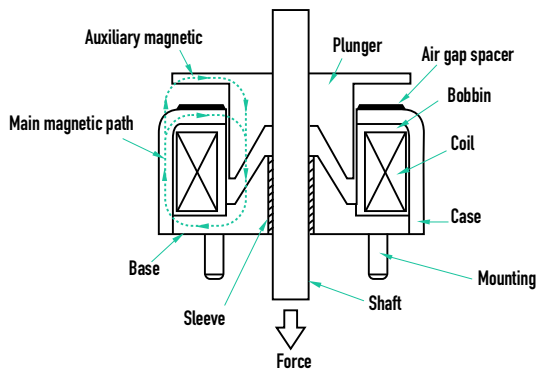
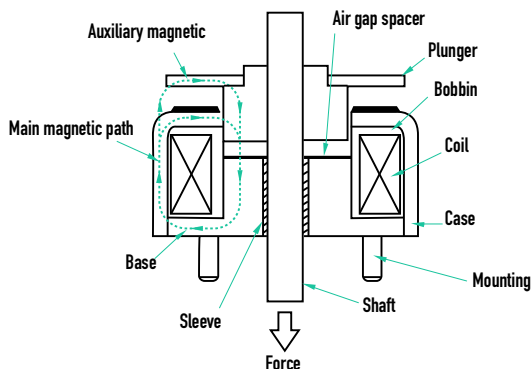

Fig. 1 Conical pole



2. Stroke and Force

The push-pull solenoid is available with 2 standard pole piece configurations. The conical pole (Fig.1) is meant for medium strokes (3-8mm). The flat pole piece (Fig. 2) is designed for short strokes (0-3mm), and where high holding force is required. Force-stroke curves for each size and configuration are shown in the catalog. For the best performance and efficiency the stroke should be kept to a minimum.

3. Operational Considerations

A) Temperature

The coil data of push-pull solenoids shows the values at ambient temperature 20°C and with a standard heat sink. If a solenoid is used at a rating shown in the coil data, it is designed so that the coil temperature rises and reaches equilibrium at approximately 85°C. In applications where the ambient temperature is higher than 20°C or the heat sink is smaller than indicated in the catalog, possible thermal damage can occur. Temperature rise tests should be performed by the customer to assure that the coil does not reach 120°C. Coils can be constructed to operate at temperatures higher than 120°C without thermal damage. Please consult the factory for details.

B) Air Gap Spacer

The push-pull solenoid uses an air gap spacer between the armature and the case. This spacer is installed to prevent the armature and base from coming into mechanical contact with each other, which would cause residual magnetism.

C) Return Spring

The push-pull solenoid does not include a return spring. Therefore, the application must include a return spring.

D) Shaft Modification

It is not recommended that the customer modify the shaft, as the shafts are fabricated before assembly. Any special configuration can be supplied. Please consult the factory for details.

E) Installation of Solenoid

The size 191C and 191F use tapped holes for mounting in the base. Caution needs to be observed that the mounting screws used to attach these solenoids are the correct length so as not to damage the coil.

[P u s h - p u l l s o l e n o i d s]

4. General Characteristics

Insulation class	Class E (120°C) Lead wire class A 105°C
Dielectric strength	AC 1000V 50/60 Hz 1 min. (at normal temperature and normal humidity)
Insulation resistance	More than 100 Mohm at DC 500V megger (At normal temperature and normal humidity)
Expected life	Standard life: 2 million cycles Extended: 10 million cycles

(Solenoid cycle life is very dependent upon side load, frequency of use, and environmental conditions. Cycle life tests should be performed by the customer.)

5. How to Select a Solenoid

Before selecting a push-pull solenoid, the following information must be determined:

A) Force

The actual force required in the application should be increased using a safety factor multiplier of 1.5 to arrive at the force value that should be used in your specification.

B) Duty Cycle

Use the aforementioned formula to calculate duty cycle. Also note the maximum on time. (See page 2)

C) Stroke

Stroke is determined by application requirements.

D) Operating Voltage

Operating DC voltage is determined by the application and voltage available.

After determining these specifications, one can find the correct size solenoid for the application, using the force-stroke characteristic tables and graphs. The coil data is also shown for different sizes of magnet wire. If the exact operating voltage is not in the coil data table, use the nearest voltage shown in the table.

When the operating voltage falls between 2 coil sizes, always use the higher AWG numbered coil so as to prevent potential thermal damage. To determine the force output of the solenoid after temperature rise, please use the amp-turn force graphs (pages 42, 43) after calculating the amp-turns.

6. Ordering Information

When ordering a push-pull solenoid, the correct part number needs to be determined from the following combination of characteristics (1-5):

- (1) M – Metric Thread
F – SAE Tread
- (2) Solenoid Size (example - 341)
- (3) C – Conical plunger
F – Flat plunger
- (4) Coil Wire Size (AWG)
- (5) P – Standard Life Bearing
PE – Extended Life Bearing
(191C, 191F, 874C and 874F have standard life bearings only.)

Example of a complete part number:

(1) (2) (3) (4) (5)
F 341 C 30 P

This part number is for a solenoid with (1) SAE threads, (2) size 341, (3) with a conical plunger, (4) with 30 Awg. coil wire, and (5) standard life bearings.

7. Labeling

For push-pull solenoids the part number labeling is as follows:

A) Standard Solenoid (no modifications).

The solenoid label will have the part number and date code.

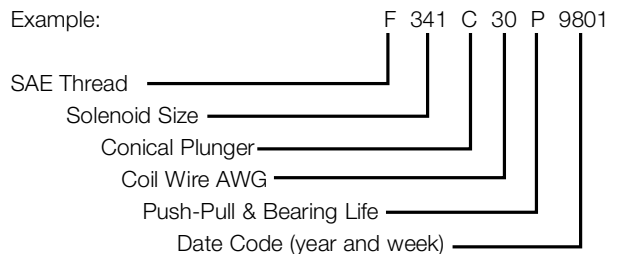

B) Special Configuration

(required for any modification to a standard design).

Any change from the standard catalog design requires that a custom part number be assigned, which will also include the date code of manufacture.

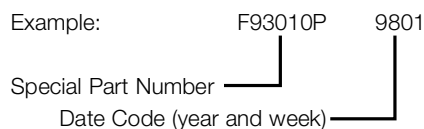

[Size 191c, 191F Push-pull solenoid]

Unit : $\frac{mm}{inch}$
SHOWN ENERGIZED

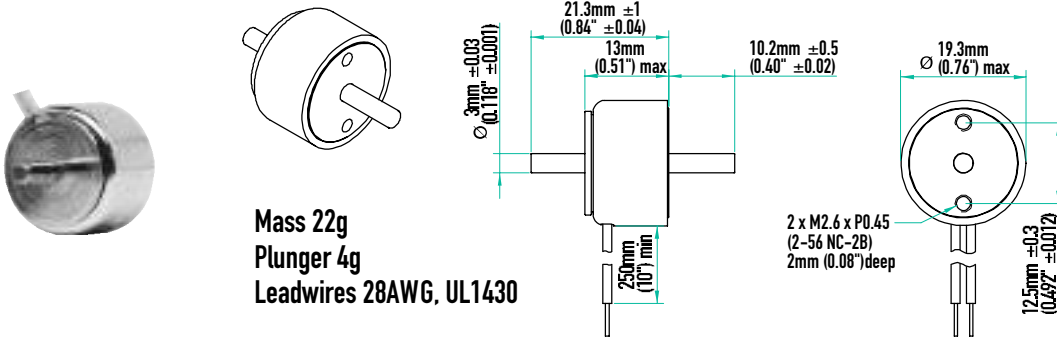

Mass 22g
Plunger 4g
Leadwires 28AWG, UL1430

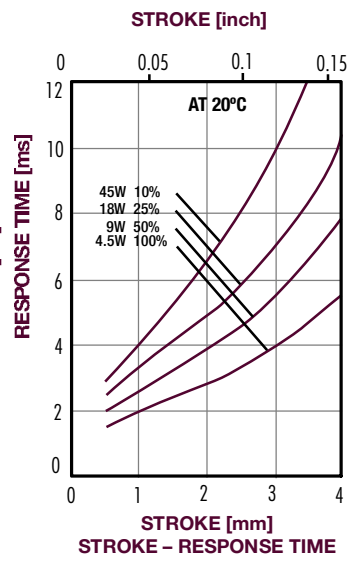
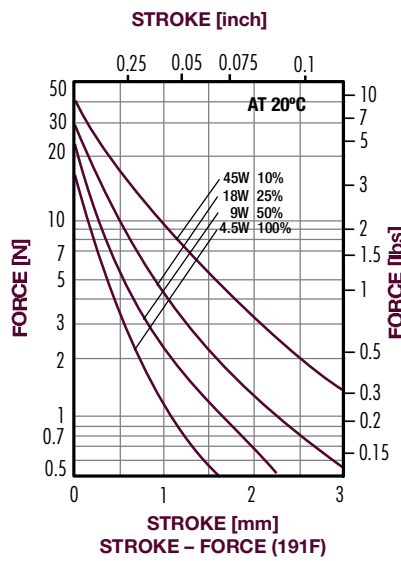
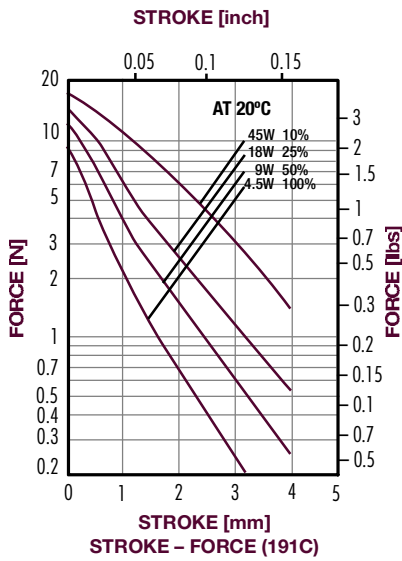

Coil Data

Heat sink : 50x50x3mm aluminum

duty cycle = $\frac{\text{"on" time}}{\text{"on" time} + \text{"off" time}} \times 100\%$			100% continuous	50% or less	25% or less	10% or less
MAX. "on" time in seconds			∞	100	36	7
watts at 20°C			4.5	9	18	45
ampere-turns at 20°C			285	403	570	901
AWG no.	resistance $\Omega \pm 10\%$ (at 20°C)	no. turns	volts DC			
30	4.02	288	4.1	5.7	8	12.1
31	5.61	324	5	7.1	9.9	15.8
32	9.09	420	6.3	8.9	12.4	19.7
33	14.95	544	8	11.3	15.7	25
34	24.06	684	10.2	14.4	20	32
35	37.1	840	12.8	18.1	25	40
36	58.51	1056	16.1	23	32	50
37	75.68	1109	19.8	28	39	62
38	118	1370	25	35	49	78
39	199	1761	33	46	64	103
40	328	2283	42	59	82	131

[Size 250C, 250F Push-pull solenoid)]

Unit : $\frac{mm}{(inch)}$
SHOWN ENERGIZED

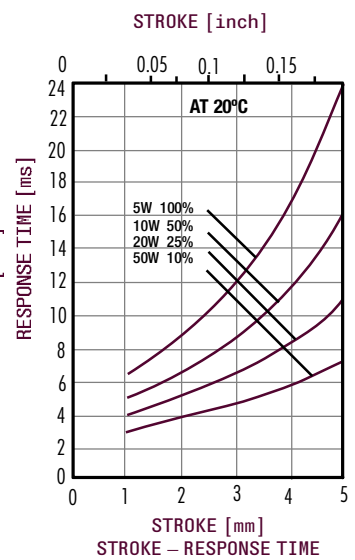
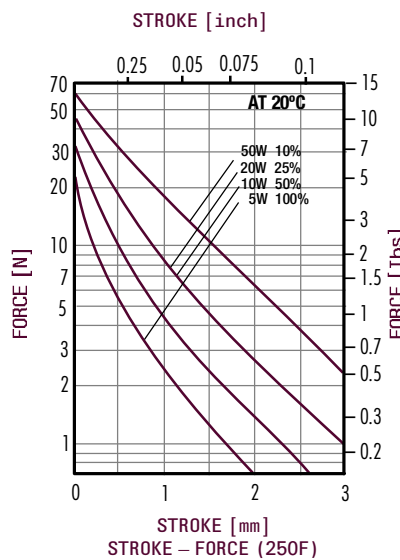
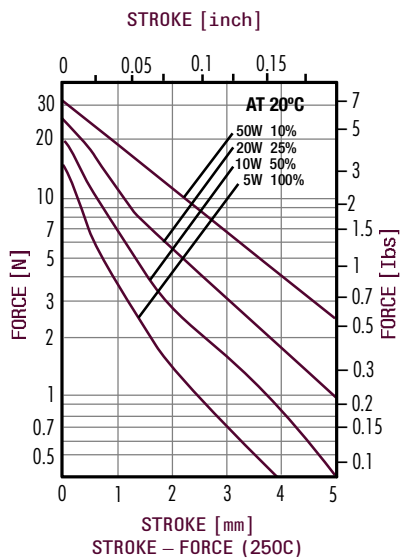
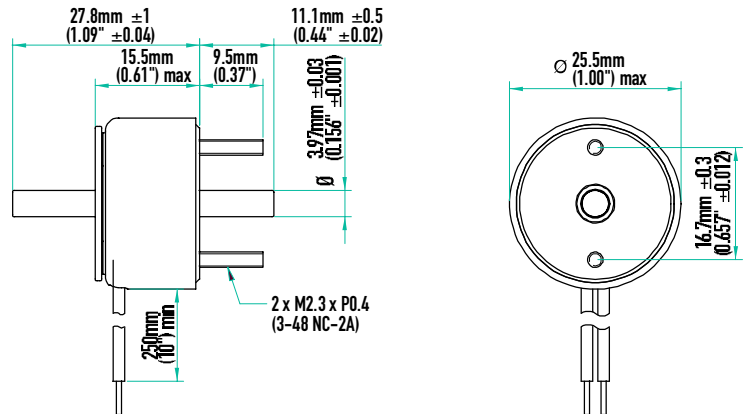
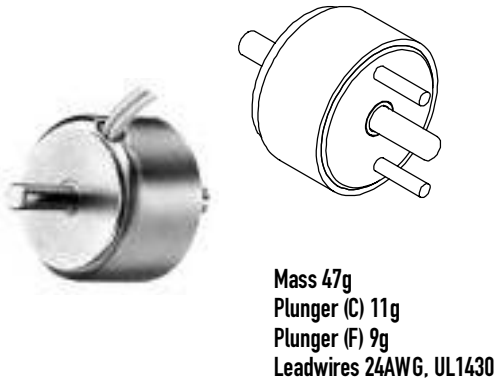

Coil Data

Heat sink : 80x80x3mm aluminum

duty cycle = $\frac{\text{"on" time}}{\text{"on" time} + \text{"off" time}} \times 100\%$			100% continuous	50% or less	25% or less	10% or less
MAX. "on" time in seconds			∞	100	36	7
watts at 20°C			5	10	20	50
ampere-turns at 20°C			340	480	680	1075
AWG no.	resistance $\Omega \pm 10\%$ (at 20°C)	no. turns	volts DC			
25	0.85	138	2.1	3.0	4.2	6.6
26	1.42	184	2.6	3.7	5.2	8.3
27	1.90	197	3.3	4.6	6.6	10.4
28	3.21	272	4.0	5.7	8.0	12.7
29	5.11	340	5.1	7.2	10.2	16.2
30	8.03	439	6.2	8.8	12.4	19.7
31	12.95	560	7.9	11.1	15.7	25
32	20.25	690	10	14.1	20	32
33	29.97	839	12.1	17.1	24	38
34	49.60	1097	15.4	22	31	49
36	110	1551	24	34	48	76
37	157	1776	30	42	60	95
38	237	2180	37	52	74	117
39	426	3110	47	66	93	147

[Size 301C, 301F Push-pull solenoid]

Unit : $\frac{mm}{(inch)}$
SHOWN ENERGIZED

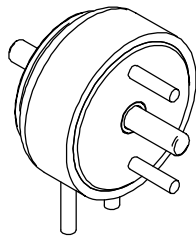
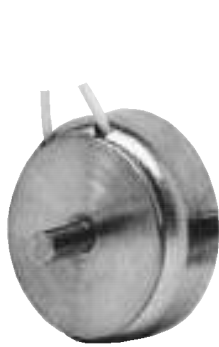

Mass 56g
Plunger (C) 16g
Plunger (F) 14g
Leadwires 24AWG, UL1430

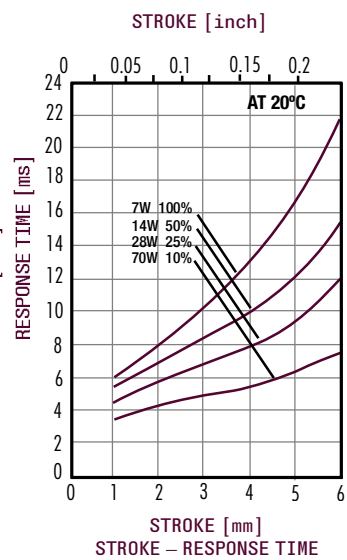
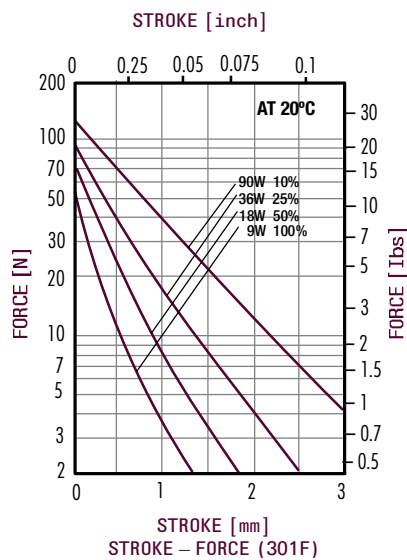
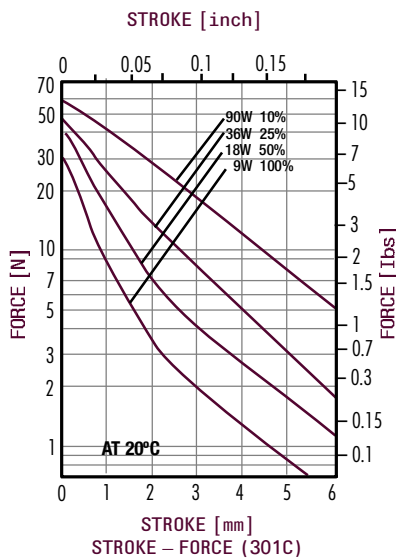
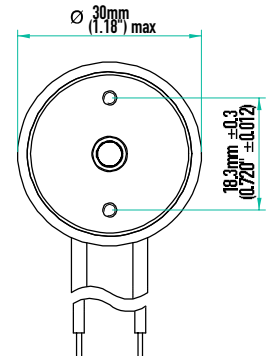
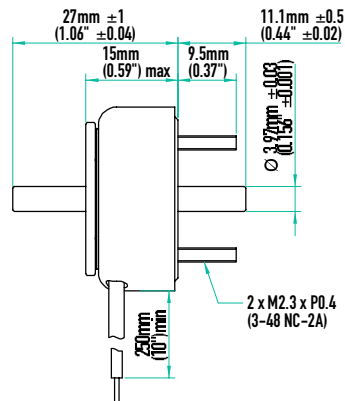

Coil Data

Heat sink : 90x90x3mm aluminum

duty cycle = $\frac{\text{"on" time}}{\text{"on" time} + \text{"off" time}} \times 100\%$			100% continuous	50% or less	25% or less	10% or less
MAX. "on" time in seconds			∞	100	36	7
watts at 20°C			7	14	28	70
ampere-turns at 20°C			425	602	849	1350
AWG no.	resistance $\Omega \pm 10\%$ (at 20°C)	no. turns	volts DC			
26	1.96	231	3.5	5	7.1	11
27	3.16	296	4.5	6.3	8.9	14
28	5.1	378	5.6	8	11	18
29	6.94	423	7.1	10	14	22
30	11	530	8.9	13	18	28
31	16.9	649	11	16	22	36
32	28.3	858	14	20	28	45
33	42.8	1036	18	25	35	56
34	69.6	1312	22	32	45	71
35	112	1674	28	39	56	89
36	148	1765	35	50	71	112
37	221	2090	45	63	89	142
38	352	2650	56	80	112	178
39	568	3380	71	100	141	224

[Size 341C, 341F Push-pull solenoid]

Unit : $\frac{mm}{(inch)}$
SHOWN ENERGIZED

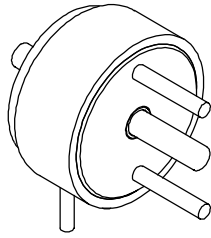
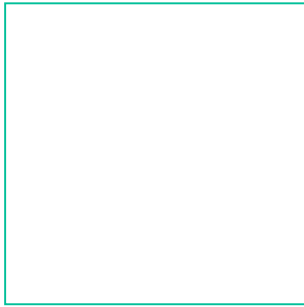

Mass 97g
Plunger (C) 23g
Plunger (F) 16g
Leadwires 24AWG, UL1430

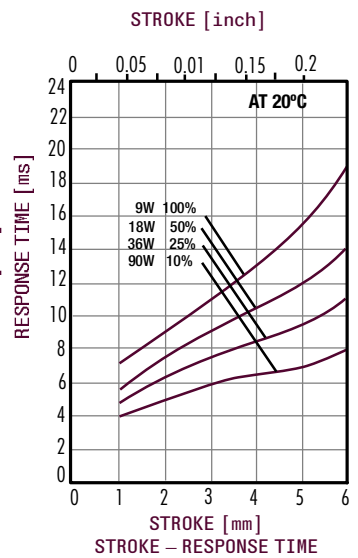
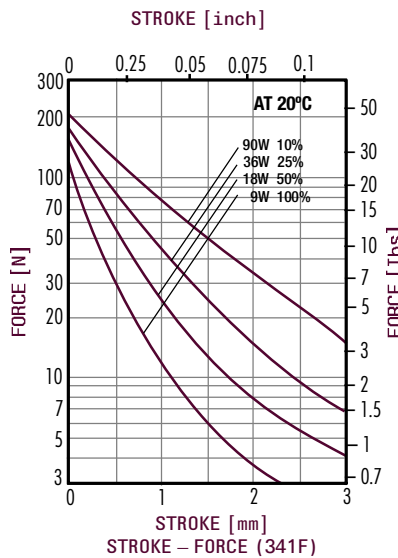
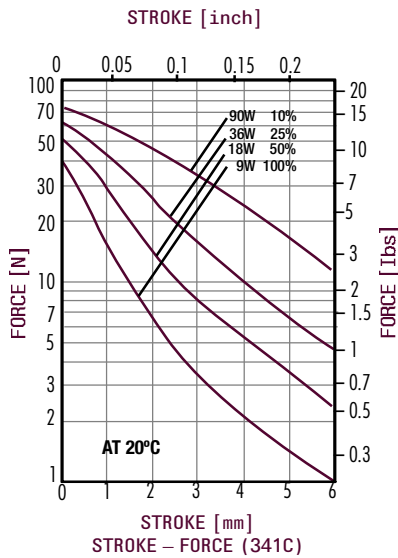
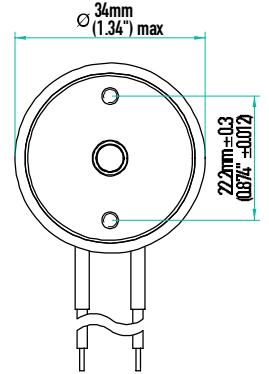
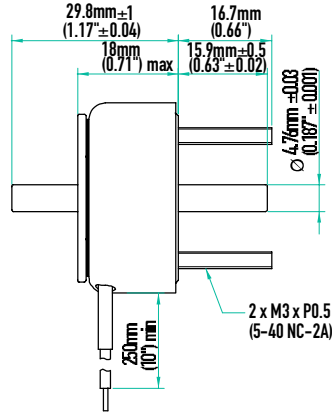

Coil Data

Heat sink : 120x120x3mm aluminum

duty cycle = $\frac{\text{"on" time}}{\text{"on" time} + \text{"off" time}} \times 100\%$			100% continuous	50% or less	25% or less	10% or less
MAX. "on" time in seconds			∞	100	36	8
watts at 20°C			9	18	36	90
ampere-turns at 20°C			535	756	1070	1690
AWG no.	resistance $\Omega \pm 10\%$ (at 20°C)	no. turns	volts DC			
25	1.97	252	4.2	5.9	8.4	13
26	3.26	328	5.3	7.5	13	17
27	5.04	405	6.7	9.4	11	21
28	8.02	510	8.4	12	17	26
29	12.21	627	10	15	21	33
30	19.2	780	13	19	26	42
31	31.8	1008	17	24	33	53
32	47	1215	21	30	42	66
33	75.3	1530	26	37	53	84
34	120.5	1900	33	47	67	105
35	198	2486	42	59	84	133
36	280	2700	53	75	106	167
37	426	3350	67	94	133	210
38	648	4050	84	118	168	264
39	1020	5050	105	149	211	33

[Size 401C, 401F Push-pull solenoid]

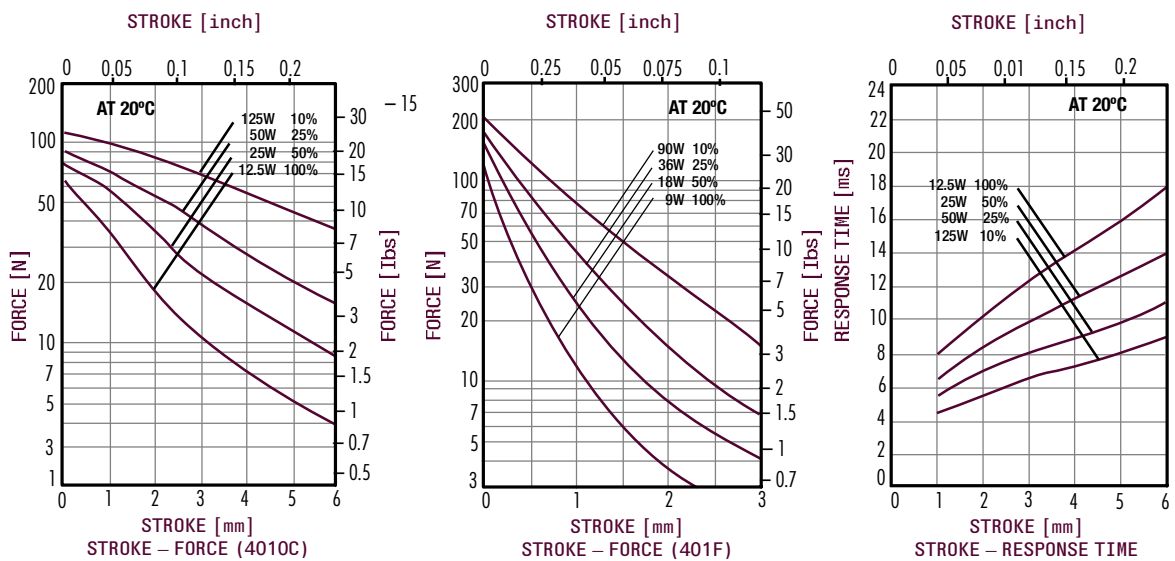
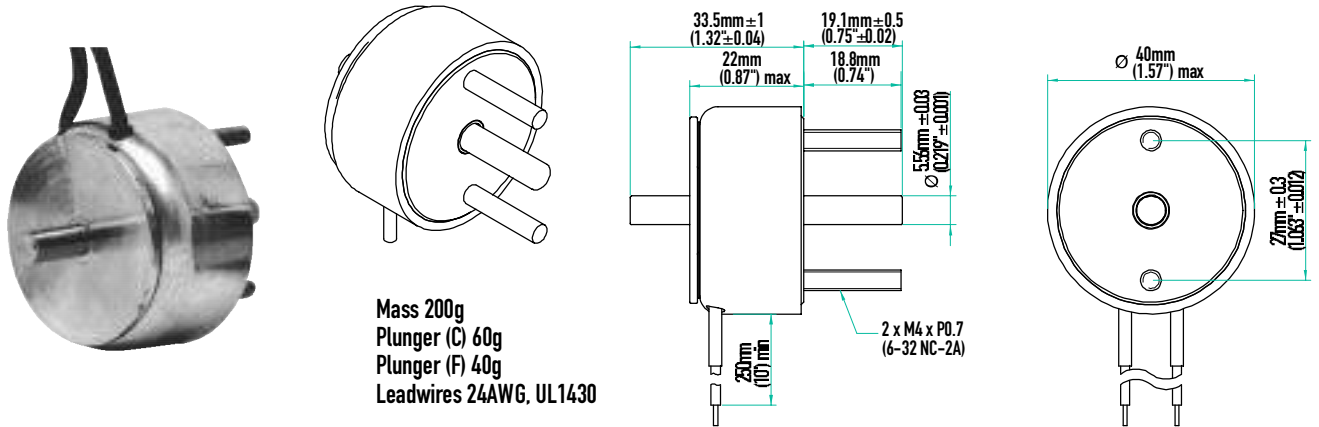

Coil Data

Heat sink : 120x120x3mm aluminum

duty cycle = $\frac{\text{"on" time}}{\text{"on" time} + \text{"off" time}} \times 100\%$			100% continuous	50% or less	25% or less	10% or less
MAX. "on" time in seconds			∞	100	36	9
watts at 20°C			12.5	25	50	125
ampere-turns at 20°C			714	1000	1425	2250
AWG no.	resistance $\Omega \pm 10\%$ (at 20°C)	no. turns	volts DC			
25	3.5	384	6.6	9.5	13	21
26	5.67	486	8.4	12	17	27
27	8.76	600	11	16	22	35
28	13.8	748	13	18	26	42
29	22.6	975	17	23	33	52
30	34.8	1190	21	30	42	67
31	56.7	1520	27	38	54	85
32	88.3	1908	35	49	70	110
33	138	2360	43	60	86	138
34	216	2904	53	75	106	168
35	351	3725	67	95	132	213
36	480	4000	85	119	169	268
37	720	4950	105	147	210	332
38	1150	6200	132	185	264	-
39	1920	8350	166	232	332	-

[Size 490F Push-pull solenoid]

Unit : $\frac{mm}{(inch)}$
SHOWN ENERGIZED

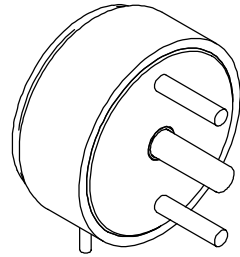
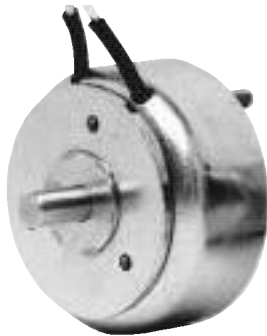

Mass 250g
Plunger 56g
Leadwires 22AWG, UL1430

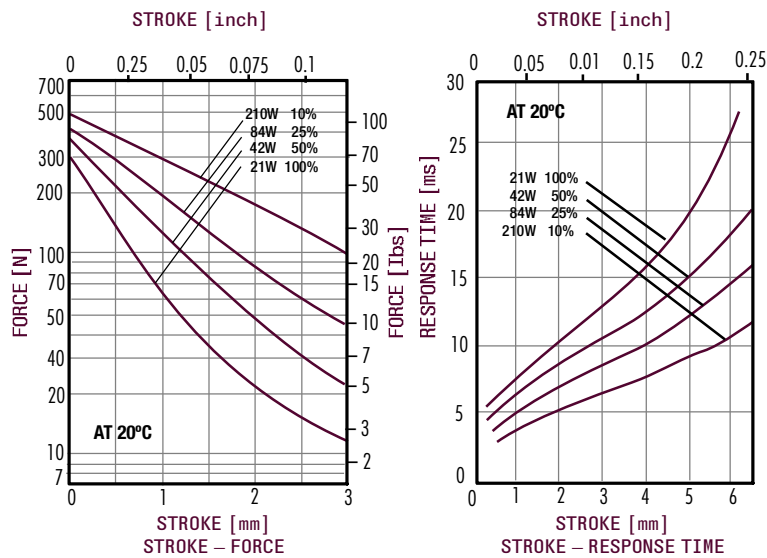
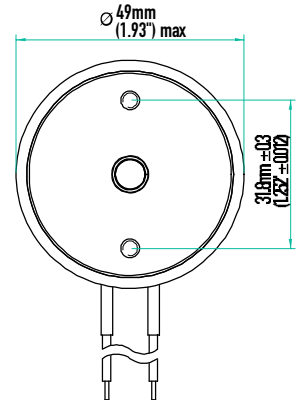
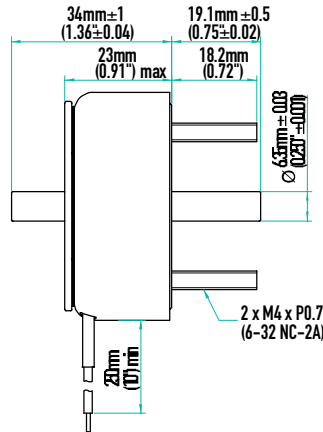

Coil Data

Heat sink : 120x120x3mm aluminum

duty cycle = $\frac{\text{"on" time}}{\text{"on" time} + \text{"off" time}} \times 100\%$			100% continuous	50% or less	25% or less	10% or less
MAX. "on" time in seconds			∞	100	36	10
watts at 20°C			21	42	84	210
ampere-turns at 20°C			842	1190	1685	2660
AWG no.	resistance $\Omega \pm 10\%$ (at 20°C)	no. turns	volts DC			
24	3.2	360	7.6	11	15	24
25	4.91	440	9.5	13	19	30
26	7.72	550	12	17	24	38
27	11.1	636	15	21	30	48
28	18.8	840	19	27	38	60
29	30.5	1088	24	34	48	76
30	44.9	1275	30	43	60	95
31	70.9	1596	38	54	76	120
32	109	1974	48	67	95	150
33	175	2496	60	85	120	190
34	270	3042	76	107	151	239
35	414	3600	95	134	190	301
36	610	4200	122	173	245	386
37	940	5200	151	213	301	-

[Size 491C, 491F Push-pull solenoid]

Unit : $\frac{\text{mm}}{\text{inch}}$
SHOWN ENERGIZED

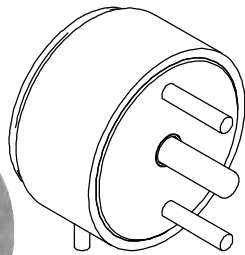

Mass 265g
Plunger (C) 70g
Plunger (F) 60g
Leadwires 22AWG, UL1430

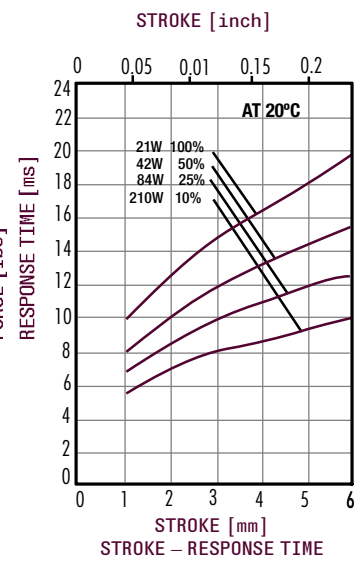
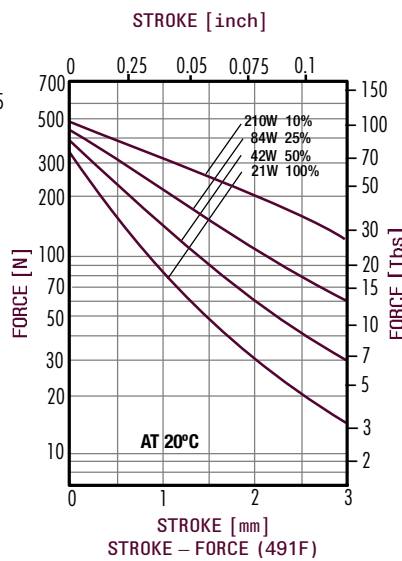
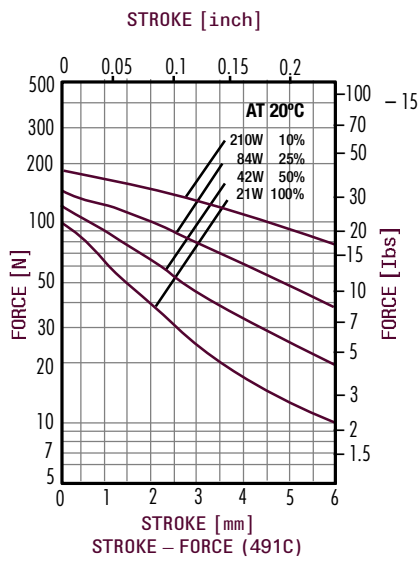
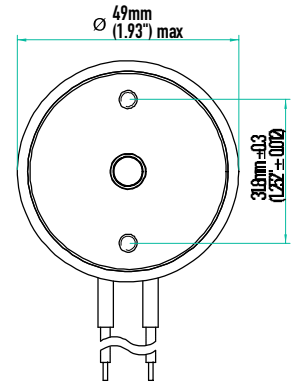
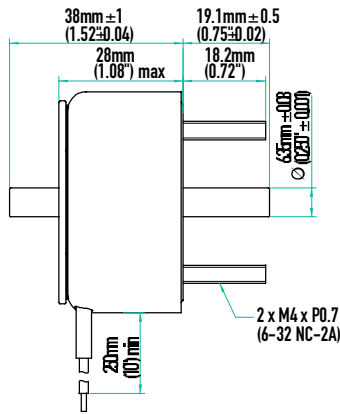

Coil Data

Heat sink : 190x190x3mm aluminum

duty cycle = $\frac{\text{"on" time}}{\text{"on" time} + \text{"off" time}} \times 100\%$			100% continuous	50% or less	25% or less	10% or less
MAX. "on" time in seconds			∞	100	36	10
watts at 20°C			21	42	84	210
ampere-turns at 20°C			1015	1440	2030	3210
AWG no.	resistance $\Omega \pm 10\%$ (at 20°C)	no. turns	volts DC			
21	1	228	4.5	6.4	8.9	14.1
22	1.68	301	5.7	8.1	11.4	17.9
23	2.7	384	7.2	10.1	14.3	23
24	4.3	486	9	12.7	18	28
25	6.66	590	11.5	16.2	23	36
26	10.3	737	14	20	28	44
27	15.7	900	17.7	25	35	56
28	26.6	1190	23	32	45	72
29	38	1380	28	40	56	89
30	62.1	1768	36	51	71	113
31	96.1	2166	45	64	90	143
32	157	2816	57	80	113	179
33	241	3432	71	101	143	226
34	364	4108	90	128	180	285
35	566	4920	117	166	234	370
36	910	6340	146	207	292	462

[Size 590C, 590F Push-pull solenoid]

Unit : $\frac{\text{mm}}{\text{(inch)}}$
SHOWN ENERGIZED

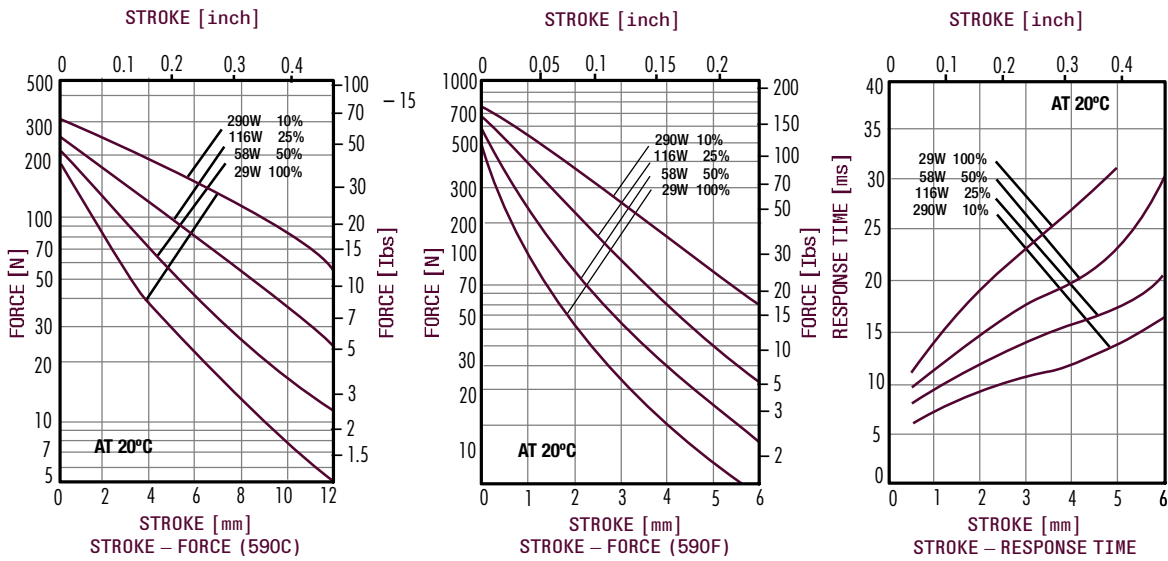
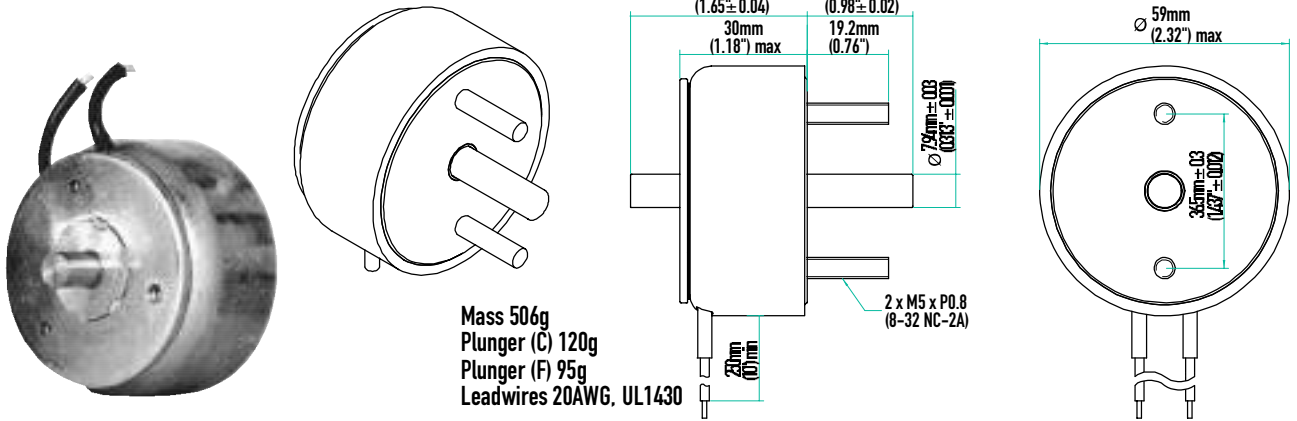

Coil Data

Heat sink : 310x310x3mm aluminum

duty cycle = $\frac{\text{"on" time}}{\text{"on" time} + \text{"off" time}} \times 100\%$			100% continuous	50% or less	25% or less	10% or less
MAX. "on" time in seconds			∞	87	36	13
watts at 20°C			29	58	116	290
ampere-turns at 20°C			1240	1760	2490	3920
AWG no.	resistance $\Omega \pm 10\%$ (at 20°C)	no. turns	volts DC			
22	2.23	336	8.3	12	16	26
23	3.6	432	10	15	21	33
24	5.24	500	13	18	26	41
25	9.51	708	16	23	33	52
26	14.4	858	21	29	41	66
27	23.7	1110	26	37	52	83
28	38.2	1411	33	47	66	104
29	54.7	1638	41	59	83	131
30	93.7	2184	52	74	110	165
31	143	2645	66	93	131	207
32	223	3328	83	117	165	261
33	338	4004	104	147	208	329
34	550	5088	131	185	262	-
35	790	5860	165	233	330	-
36	1233	7260	208	294	-	-

[Size 591C, 591F Push-pull solenoid]

Unit : $\frac{\text{mm}}{\text{inch}}$
SHOWN ENERGIZED

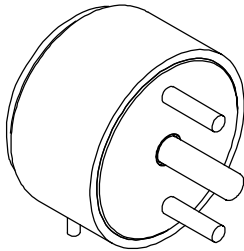

Mass 620g
Plunger (C) 145g
Plunger (F) 140g
Leadwires 20AWG, UL1430

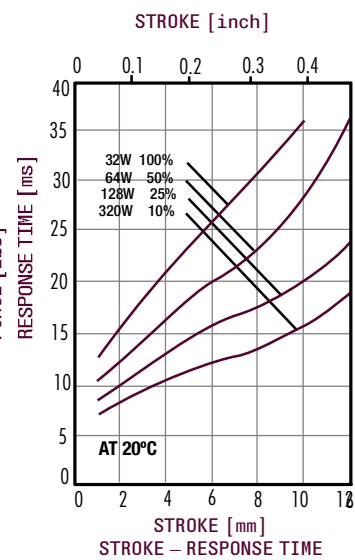
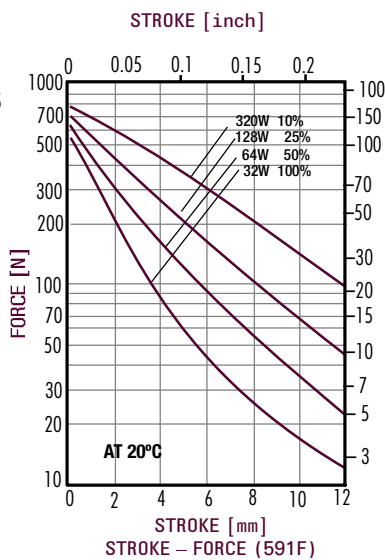
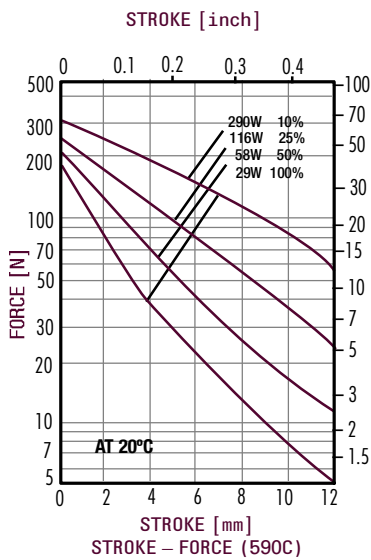
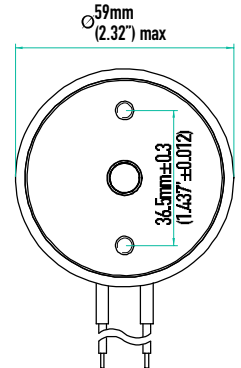
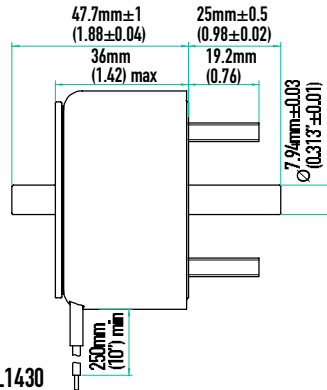

Coil Data

Heat sink : 310x310x3mm aluminum

duty cycle = $\frac{\text{"on" time}}{\text{"on" time} + \text{"off" time}} \times 100\%$			100% continuous	50% or less	25% or less	10% or less
MAX. "on" time in seconds			∞	87	36	13
watts at 20°C			32	64	128	320
ampere-turns at 20°C			1480	2080	2940	4620
AWG no.	resistance $\Omega \pm 10\%$ (at 20°C)	no. turns	volts DC			
20	1.23	295	6.2	8.7	12.3	19.3
21	1.75	340	7.6	10.7	15.1	24
22	2.79	446	9.3	13	18.4	29
23	4.54	567	11.9	16.7	24	37
24	6.93	690	14.9	21	30	46
25	12.5	910	20.2	29	40	63
26	18.4	1120	24	34	48	76
27	33.4	1500	33	46	65	76
28	46.3	1750	39	55	78	103
29	74.5	2232	46	69	98	154
30	125.5	2940	63	86	126	197
31	199	3611	82	115	162	255
32	302	4350	103	144	204	321

[Size 700C, 700F Push-pull solenoid]

Unit : $\frac{\text{mm}}{\text{inch}}$
SHOWN ENERGIZED

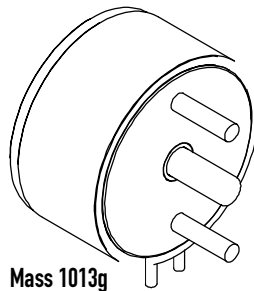

Mass 1013g
Plunger (C) 268g
Plunger (F) 285g
Leadwires 20AWG, UL1430

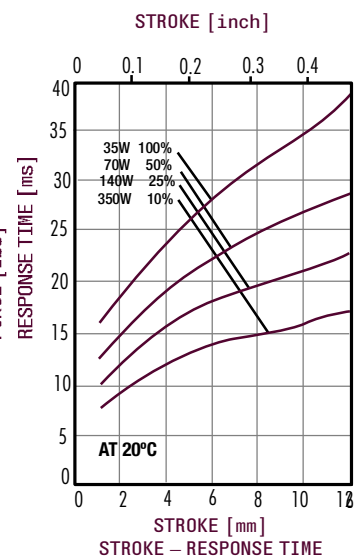
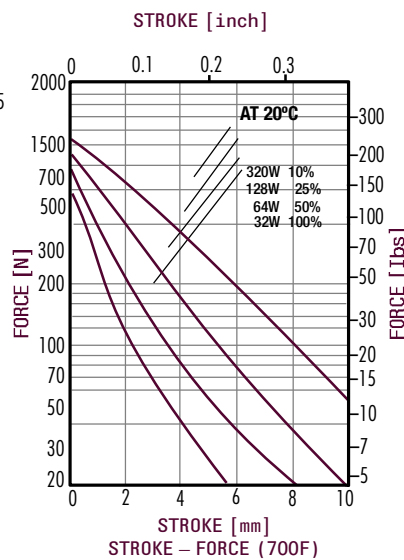
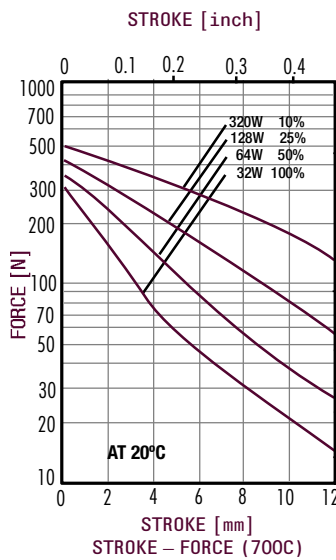
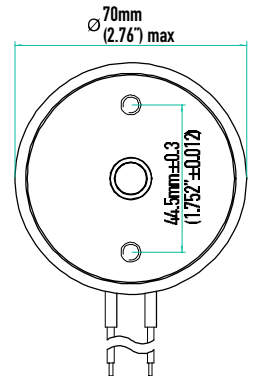
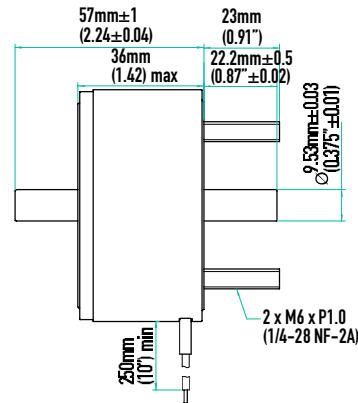

Coil Data

Heat sink : 390x390x3mm aluminum

duty cycle = $\frac{\text{"on" time}}{\text{"on" time} + \text{"off" time}} \times 100\%$			100% continuous	50% or less	25% or less	10% or less
MAX. "on" time in seconds			∞	80	38	16
watts at 20°C			35	70	140	350
ampere-turns at 20°C			1570	2230	3150	5000
AWG no.	resistance Ω±10% (at 20°C)	no. turns	volts DC			
20	1.88	368	8	11	16	26
21	3.01	468	10	14	20	32
22	4.82	580	13	18	26	41
23	8.1	780	16	23	33	52
24	12.3	949	20	29	41	65
25	19	1148	26	37	52	83
26	30.8	1472	33	46	66	105
27	48.8	1854	41	59	83	132
28	81.1	2436	52	75	105	166
29	121	2944	64	92	130	206
30	190	3650	82	118	166	264
31	275	4175	104	147	209	331
32	440	5792	119	170	240	-
33	735	7000	165	235	331	-

[Size 870C, 870F Push-pull solenoid]

Unit : $\frac{\text{mm}}{\text{inch}}$
SHOWN ENERGIZED

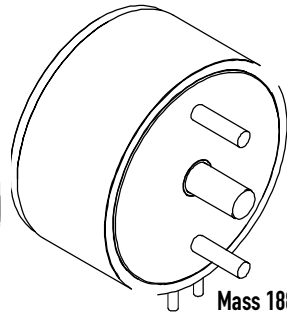

Mass 1885g
Plunger (C) 495g
Plunger (F) 480g
Leadwires 18AWG, UL1430

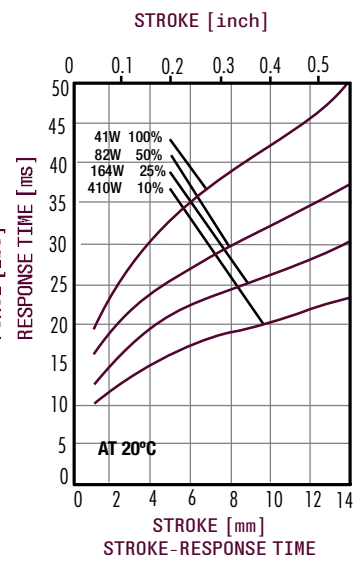
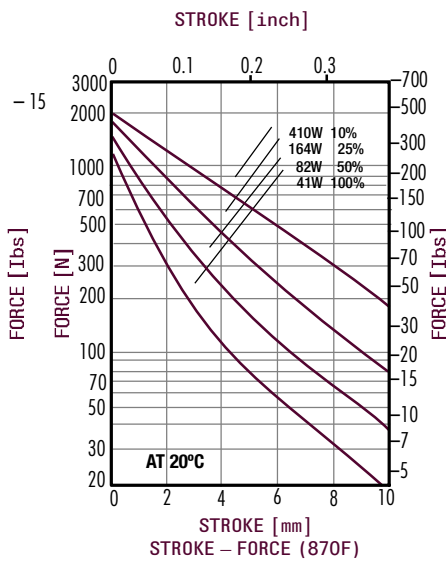
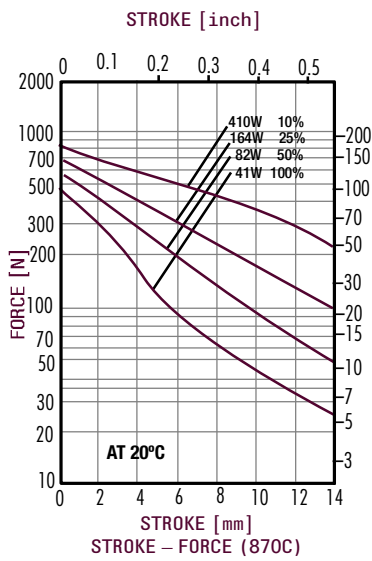
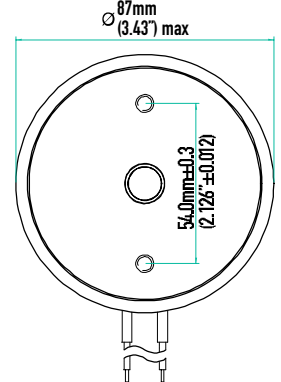
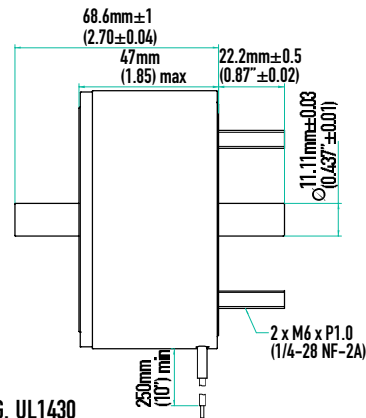

Coil Data

Heat sink : 520x520x3mm aluminum

duty cycle = $\frac{\text{"on" time}}{\text{"on" time} + \text{"off" time}} \times 100\%$			100% continuous	50% or less	25% or less	10% or less
MAX. "on" time in seconds			∞	72	43	20
watts at 20°C			41	82	164	410
ampere-turns at 20°C			1910	2750	3810	5950
AWG no.	resistance Ω±10% (at 20°C)	no. turns	volts DC			
18	1.47	368	7.6	11	15	24
19	2.3	459	9.6	14	19	30
20	3.64	580	12	17	24	37
21	5.57	704	15	22	30	47
22	9.5	936	19	28	39	60
23	14.3	1134	24	35	48	75
24	23.3	1456	30	44	61	75
25	37.1	1836	39	56	77	95
26	58.6	2300	49	70	97	120
27	89.9	2816	61	88	121	152
28	139	3456	76	111	153	239
29	227	4480	98	138	193	239
30	376	5792	124	177	248	387
31	515	6600	148	212	297	-
32	785	7850	188	275	385	-
33	1130	9050	237	339	-	-

[Size 874C, 874F Push-pull solenoid]

Unit : $\frac{\text{mm}}{\text{inch}}$
SHOWN ENERGIZED

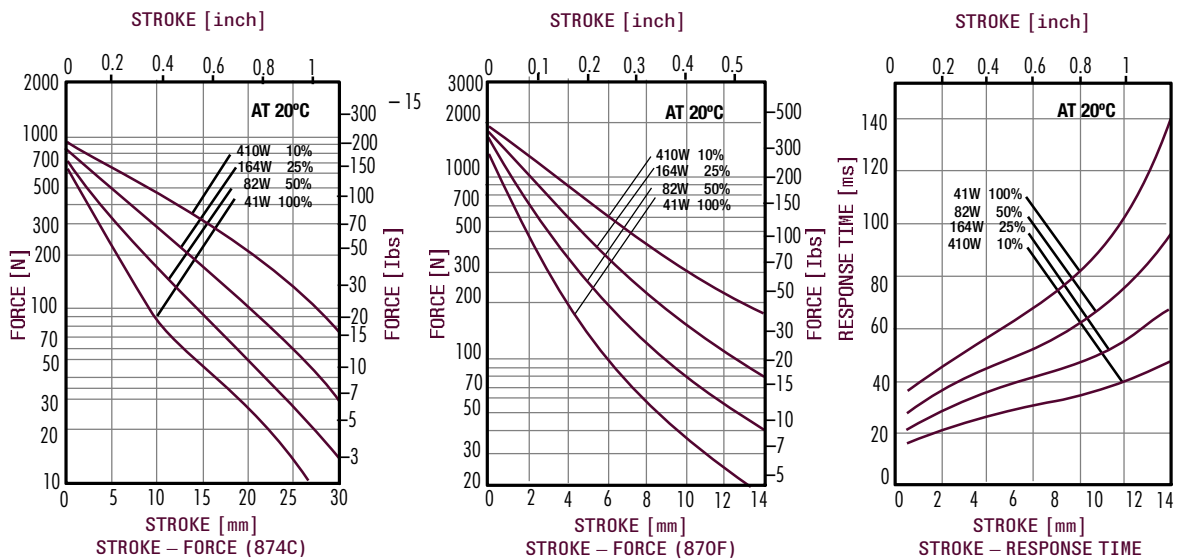
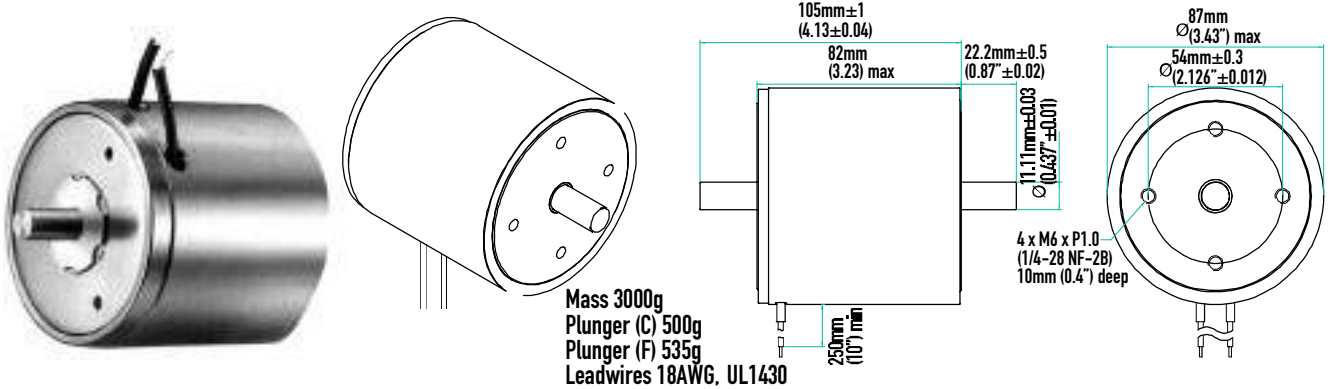

Coil Data

Heat sink : 520x520x3mm aluminum

duty cycle = $\frac{\text{"on" time}}{\text{"on" time} + \text{"off" time}} \times 100\%$			100% continuous	50% or less	25% or less	10% or less
MAX. "on" time in seconds			∞	72	43	20
watts at 20°C			41	82	164	410
ampere-turns at 20°C			2590	3663	5180	8190
AWG no.	resistance $\Omega \pm 10\%$ (at 20°C)	no. turns	volts DC			
18	2.54	630	10	15	21	33
19	4.15	828	13	18	26	41
20	6.38	1047	16	22	32	50
21	11.14	1408	20	29	41	65
22	16.8	1723	25	36	51	80
23	25.8	2046	33	46	65	103
24	42.5	2711	41	57	81	128
25	66.3	3279	52	74	105	166
26	105	4151	66	93	131	207
27	165	5190	82	116	165	260
28	261	6500	104	147	208	329
29	422	8340	131	185	262	-
30	664	10230	168	238	336	-
31	968	12410	202	286	-	-
32	1520	15200	259	366	-	-