

[Latching solenoids]

Also known as Bi-stable, Keep, Remanence, or Self-Holding Solenoid]

General Discussion

Latching solenoids exhibit magnetic attraction between plunger (moveable iron component) and pole piece (fixed iron component) with no electrical power applied. They do this by incorporating permanent magnet blocks in the magnetic circuit that drive magnetic flux around the iron path. Depending on polarity, the electrical current that is applied to the coil can either reinforce the flux due to permanent magnets to develop a stronger pull-in force, or can counter the PM flux to reduce the overall magnetic flux and pull-in force.

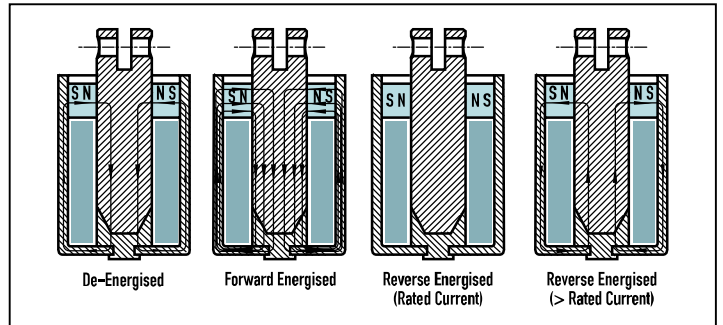

The ability to drive a latching solenoid with short pulses of current confers several important advantages on these devices:

- Power consumption is zero to hold in either end position – this is advantageous for systems with limited power supply such as battery-powered devices, or devices powered by telephone line power, or solar power.
- Power dissipation (heat) is zero in the holding condition – this is advantageous to handling temperature-sensitive materials such as photo-chemicals, blood products, or chemical reagents.
- There is no radiated electrical noise in the holding position (there is a fixed magnetic field due to the permanent magnets); this can be advantageous in sensitive measuring circuits.
- The ability to hold the closed position without power, can allow higher power to be applied during the excitation pulse for a given size of device without causing heating problems, this can allow for faster operating speed, or allow for a smaller device to be used to move the load in a given application.

The latching solenoid is ideally suited to applications where the ‘moving’ time is very short compared to holding time in the closed position, and where the system may be required to maintain either the open position or the closed (pulled in) position for a prolonged period of time.

It should be recognised that latching solenoids are unsuited to applications requiring ‘fail-safe’ operation (where the system should move to a known state in the event of power failure) unless complex drive circuits with energy storage are employed. Where fail-safe operation is required alternative solutions (such as pick & hold circuit) should be considered.

In an application where the load is acting to draw the plunger away from the solenoid end pole, it is possible to construct a bi-stable system which will remain either in the fully pulled in position (held by magnetic force due to permanent magnets), or in the fully extended (held against magnetic attraction by the load) position with no power applied. In systems where the load does not act in an appropriate direction to achieve this, or is insufficient to overcome the magnetic attraction, a bi-stable design may be realised by the addition of a spring to provide the extending force.

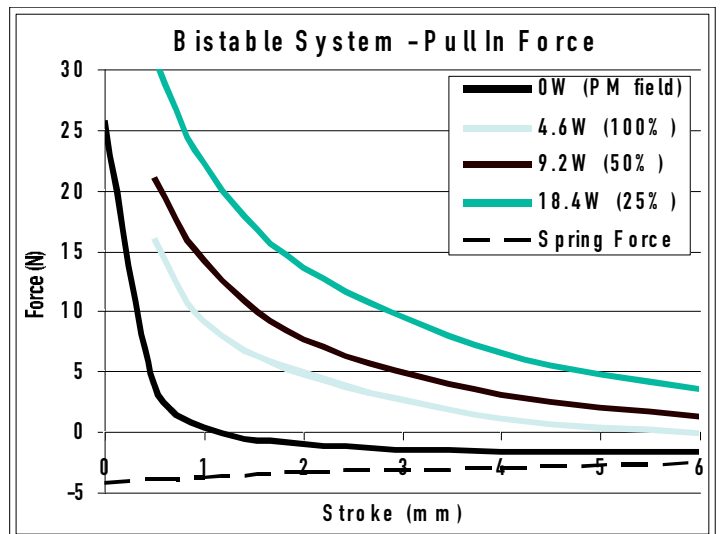

[Latching solenoids

Also known as Bi-stable, Keep, Remanence, or Self-Holding Solenoid]

An excitation current applied in the positive sense will cause the magnetic attraction force to increase; the solenoid will 'pull in' to the energised (0mm) position.

An excitation current applied in the reverse sense will neutralise the field due to permanent magnets and reduce the magnetic attraction force, allowing the load to draw the plunger out to the extended (open) position (determined by customer designed mechanical stop). It should be noted that there is an optimum value of 'release current' in the reverse direction at which the resultant magnetic force is a minimum. This value, and the required minimum load to ensure reliable release, are important parameters to select a latching solenoid. If the reverse current is increased greater than this value, the 'pull-in' force will again increase as flux is driven through the iron circuit in the reverse direction.

Modification

The following modifications can be made to bi-stable solenoids

- Coil winding – the coil can be wound for other winding resistance, or with a centre-tap to allow a simpler drive circuit to be used
- Mechanical modification to the plunger to facilitate attachment to the load
- Spring – a return spring can be incorporated for bi-stable operation. This is normally fitted externally to the solenoid body
- A stronger / weaker magnet – the use of stronger magnet material allows higher force to be developed by a given size of solenoid, and can offer better efficiency where high force or speed is required. The graph shows how use of a stronger magnet material affects release force and current.

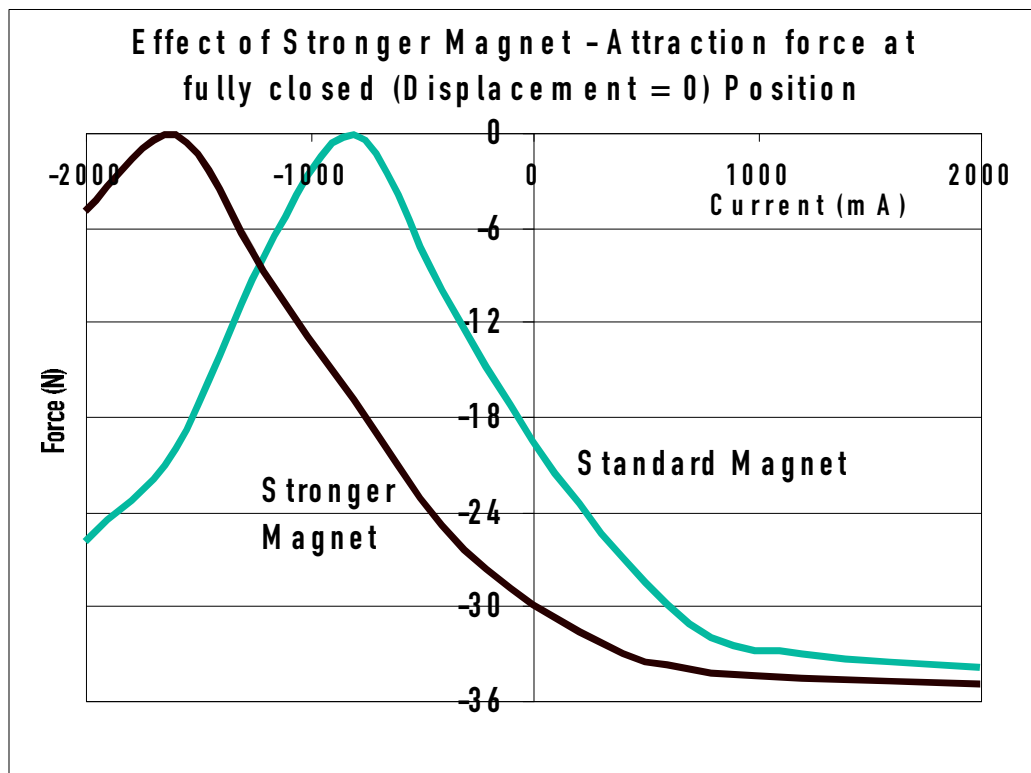

[Latching solenoids]

Also known as Bi-stable, Keep, Remanence, or Self-Holding Solenoid]

Driving Latching Solenoids

Latching Solenoids require current to be applied in either a forward or reverse polarity to achieve 'pull-in' and 'release' operation. This is usually achieved through the use of an 'H Bridge' drive circuit. This may be implemented using discrete components, or using integrated devices produced by many i.c. manufacturers for motor drives. In the circuit shown below, transistors T1 & T4 are switched on to provide forward excitation for 'pull-in' operation, T2 & T3 are switched on to provide reverse excitation for 'release' operation.

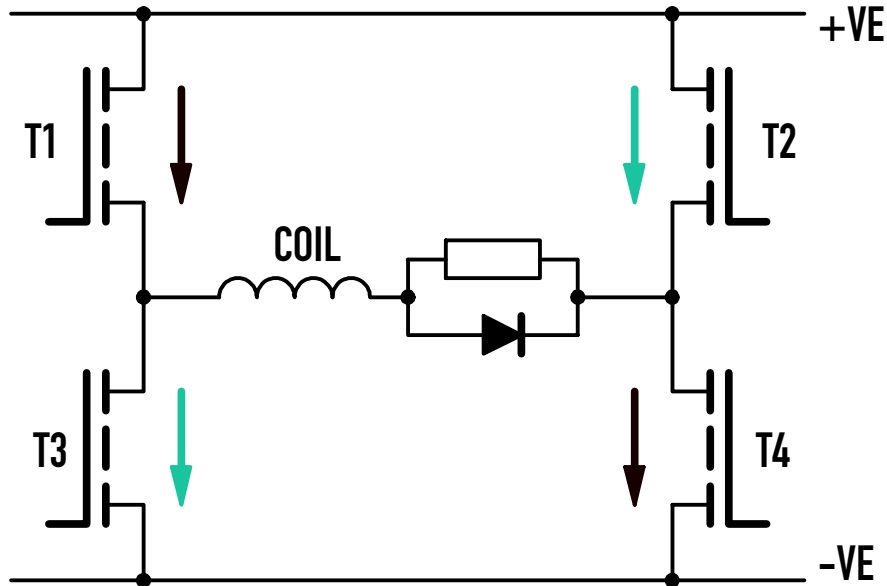

Single coil Latching Solenoids

Single-coil latching solenoids are driven with forward or reverse polarity current applied to the coil. Where high-power is applied in the forward direction to meet high force or fast actuation requirement, it may be necessary to limit current in the reverse direction to achieve optimum release characteristic. This can be done by simply using resistor / diode circuit, or more efficiently using PWM current control.

2-coil Latching Solenoids

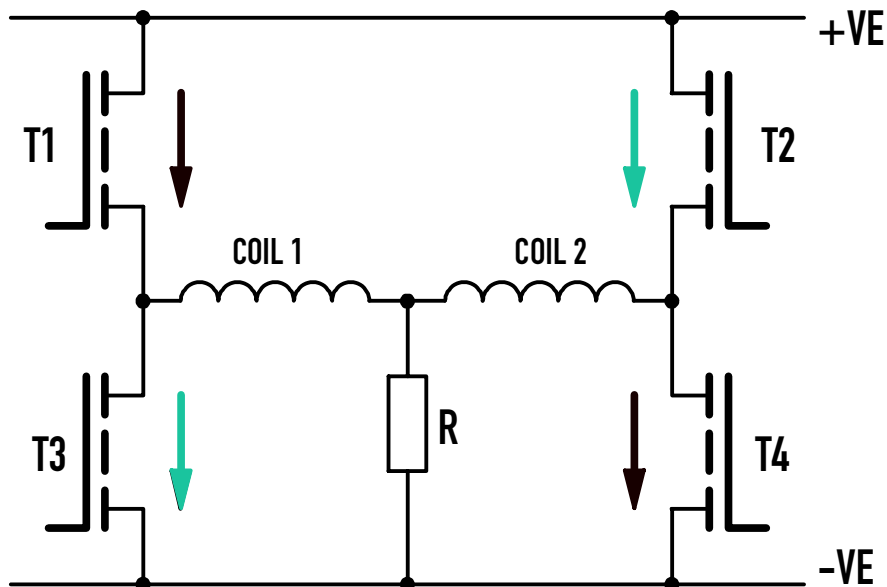

[Latching solenoids]

Also known as Bi-stable, Keep, Remanence, or Self-Holding Solenoid]

2-coil Latching Solenoids (cont)

Energising both coils simultaneously best drives 2-coil devices; the 'release' coil is energised in the reverse direction at 'release' current, the 'pull-in' coil is energised in the forward direction at a current determined by actuation force and speed requirements. The different current required in the two coils can most simply be developed using a drive circuit as shown. The resistor connected to negative supply rail acts in parallel with the 'release' coil to divert some current, limiting the release current to its optimal value. The value for this resistance is calculated as follows:

$$R = (I_{\text{Release}} \times R_{\text{Coil2}}) / (V_{\text{Supply}} - [2 \times I_{\text{Release}} \times R_{\text{Coil}}])$$

More efficient operation can be realised if the current regulation for 'release' coil is realised using a PWM drive circuit, at the cost of increased circuit complexity and cost.

Latching solenoids of T1L or T2L series are produced in a conveyor production line and are the most cost-effective solution where production batches of >5k pcs are used. Standard catalogue models can be supplied in smaller lot sizes.

Devices of SH1L and SH2L series are produced using small-cell production method and offer more flexibility for modification of the solenoid in smaller volumes. Modification such as different coil winding, changed mechanical attachment to machined parts, or rare-earth magnets can be implemented for quantities of 500-1k pcs.

TSB series solenoids are best suited to applications with high duty cycle requirements. The frame construction of these is stronger than other types and better able to withstand repeated impact cycles. With special surface treatments on the sliding and impact surfaces of the solenoid, these can be modified so as to withstand up to 5M or more operating cycles.

When to use a Latching Solenoid

[Latching Solenoids develop attraction force in the de-energised condition - they will pull-in to or hold the de-energised position without any power being supplied.

Latching solenoids confer greatest benefits in applications where the solenoid can be required to hold in either state for an indefinite period. In applications where 'on' time is always short, a latching solenoid is unlikely to be a good solution.

The lower diagram exhibits the two characteristics that typify an application suitable for a latching solenoid.

- Fast Response Time (or high force) is required - this demands a high excitation current.
- 'ON' time is much longer than the response time - typically this is indefinite and duty must be considered to be 100%.

In this case, the high current necessary to meet speed requirement with a conventional solenoid can lead to power consumption and/or heat dissipation problems. If a latching solenoid is used, the ability to switch off current during most of the cycle reduces power, and permits very high pulse power to be applied to meet speed and force requirements without power consumption or heat dissipation problems.]

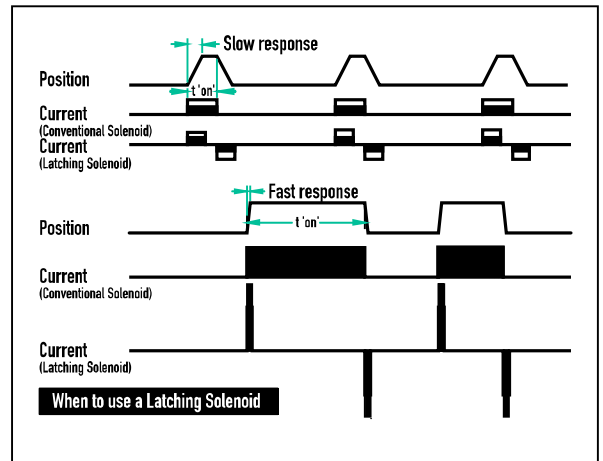

[Latching solenoids]

Also known as Bi-stable, Keep, Remanence, or Self-Holding Solenoid]

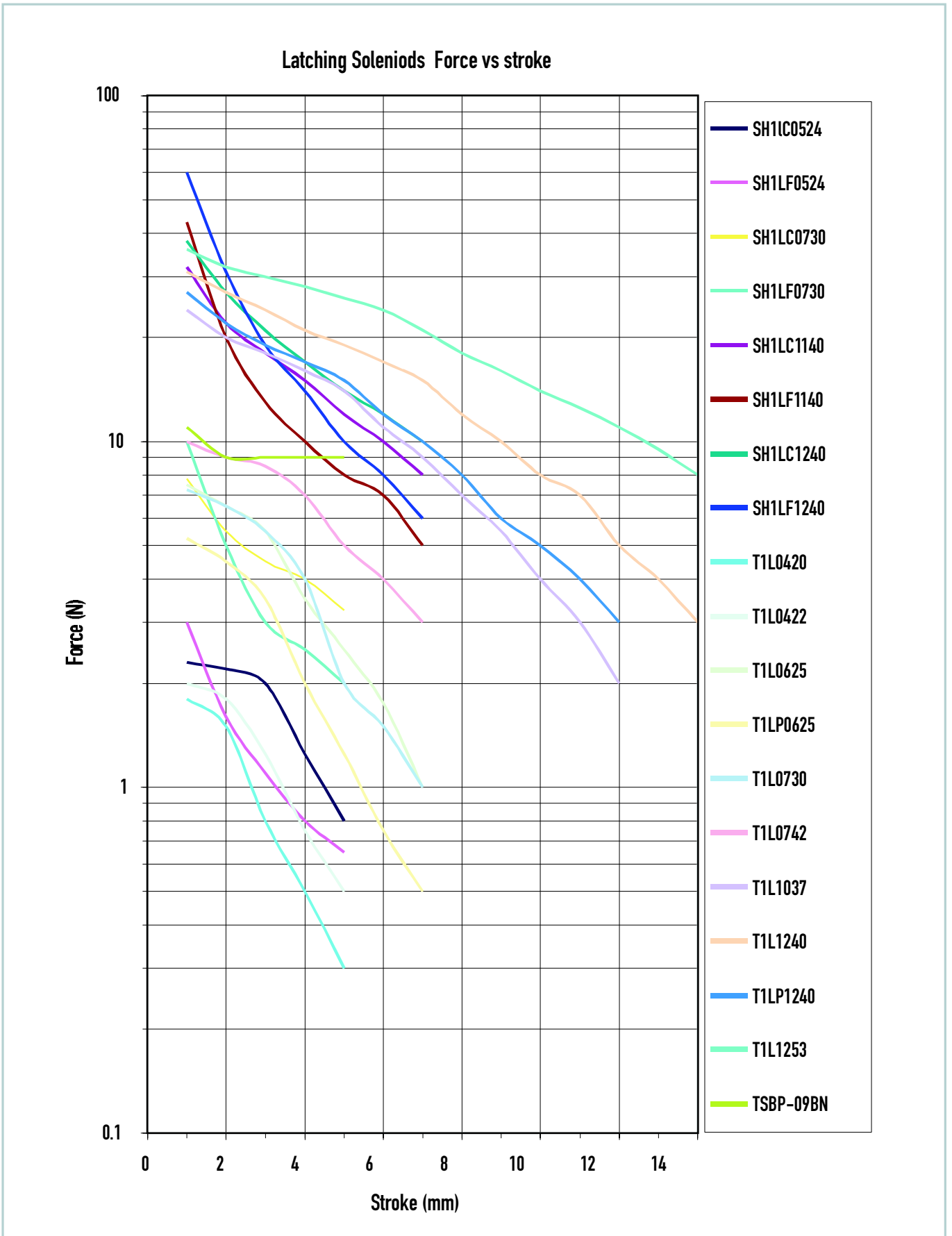

[Latching solenoids]

SH1LC/F-0524

Part Number	Duty Cycle		25%	Release Current
	Maximum 'ON' time		5 secs	
	Power Consumption (W @ 20°C)		8.4	
	Ampere-Turns @ 20°C		452	
	Resistance (Ω @ 20°C)	Coil Turns	V DC	
SH1LCO524-06 SH1LFO524-06	4.3	340	6	360mA
SH1LCO524-12 SH1LFO524-12	17.1	630	12	200mA
SH1LCO524-24 SH1LFO524-24	68.6	1,260	24	100mA

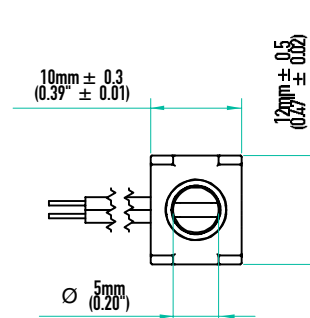
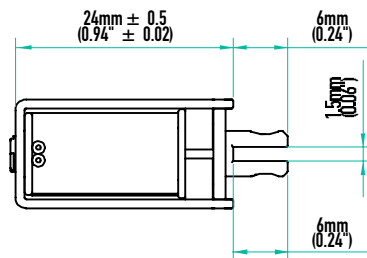
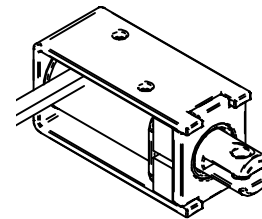
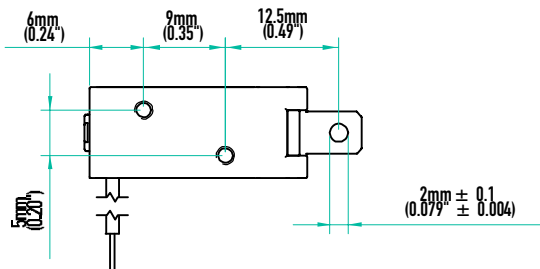
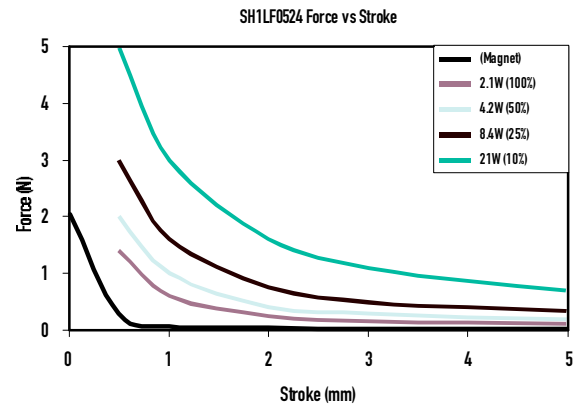
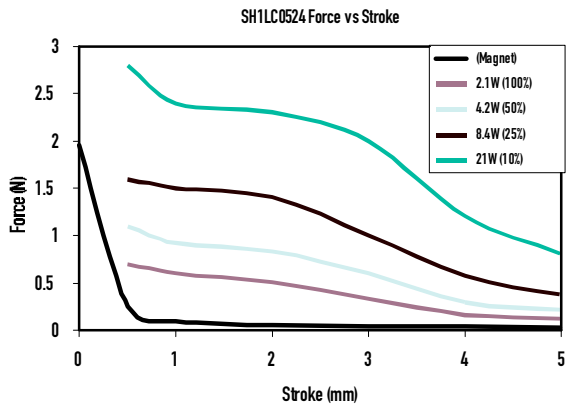

[Latching solenoids]

SH1LC/F-0730

Part Number	Duty Cycle		25%	Release Current
	Maximum 'ON' time		10	
	Power Consumption (W @ 20°C)		9.6	
	Ampere-Turns @ 20°C		614	
	Resistance (Ω @ 20°C)	Coil Turns	V DC	
SH1LCO730-06 SH1LFO730-06	3.8	385	6	650mA
SH1LCO730-12 SH1LFO730-12	15	780	12	320mA
SH1LCO730-24 SH1LFO730-24	60	1,530	24	160mA

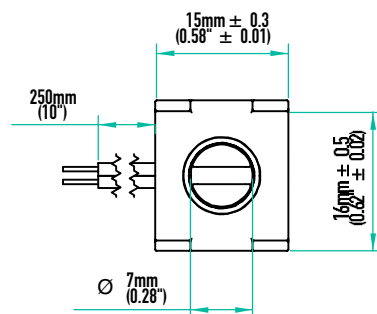
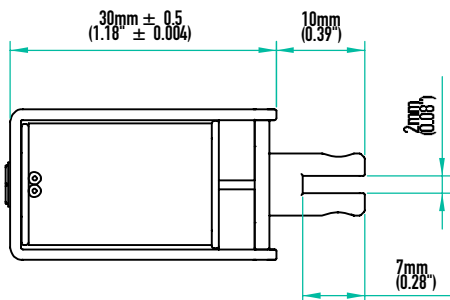
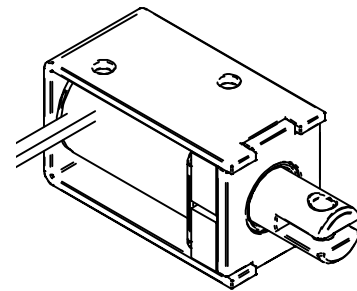
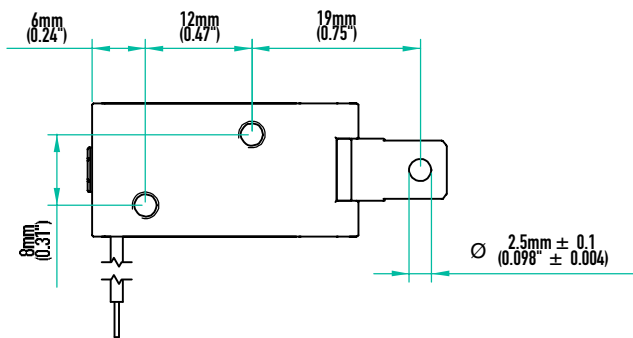
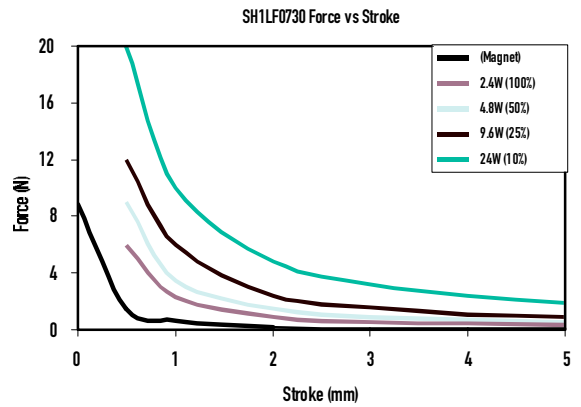
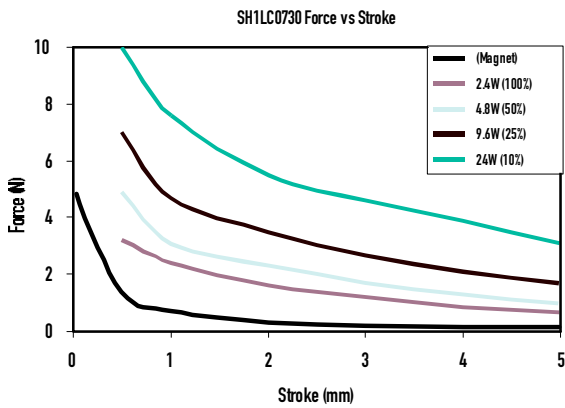

[Latching solenoids]

SH1LC/F-1140

Part Number	Duty Cycle			Release Current
	25%			
	Maximum 'ON' time			
	Power Consumption (W @ 20°C)			
	Ampere-Turns @ 20°C			
	Resistance (Ω @ 20°C)	Coil Turns	V DC	
SH1LC1140-06 SH1LF1140-06	2.1	340	6	1,060mA
SH1LC1140-12 SH1LF1140-12	8.2	630	12	560mA
SH1LC1140-24 SH1LF1140-24	32.7	1,360	24	260mA

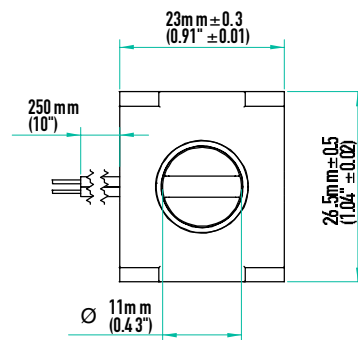
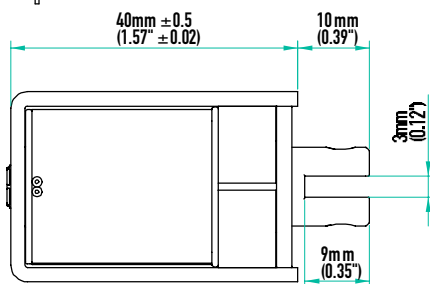
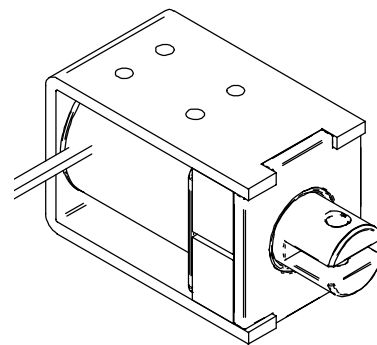
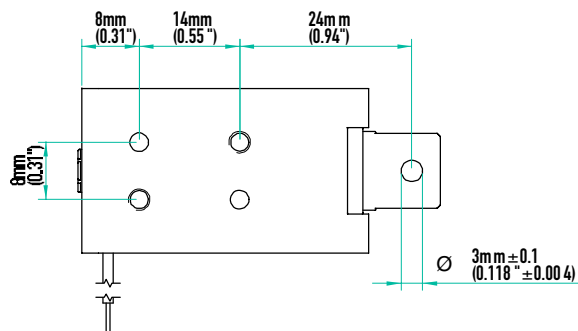
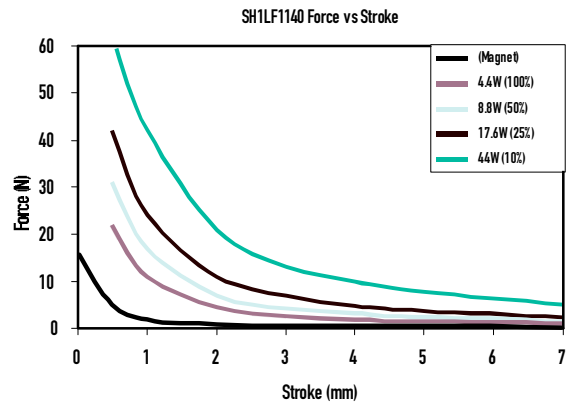
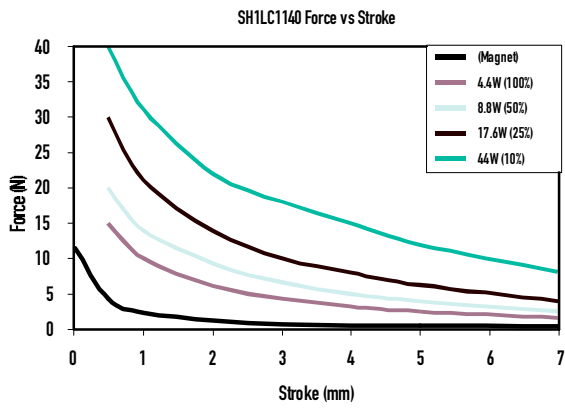

[Latching solenoids]

SH1LC/F-1240

Part Number	Duty Cycle		25%	Release Current
	Maximum 'ON' time		20	
	Power Consumption (W @ 20°C)		18.4	
	Ampere-Turns @ 20°C		979	
	Resistance (Ω @ 20°C)	Coil Turns	V DC	
SH1LC1240-06 SH1LF1240-06	2	320	6	1,620mA
SH1LC1240-12 SH1LF1240-12	7.8	630	12	820mA
SH1LC1240-24 SH1LF1240-24	31.3	1,315	24	400mA

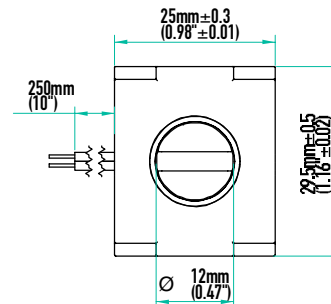
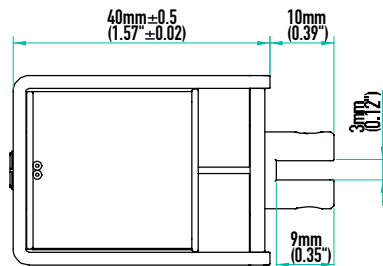
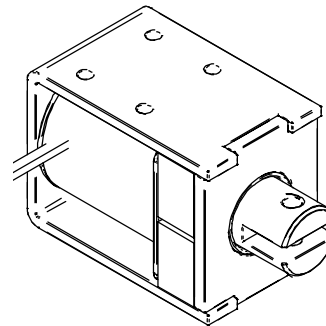
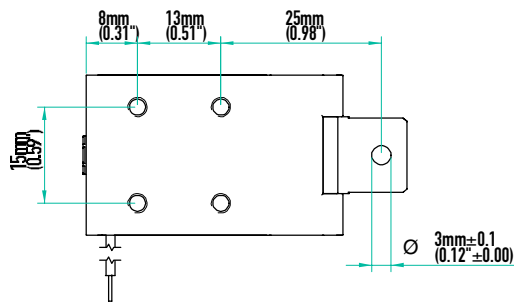
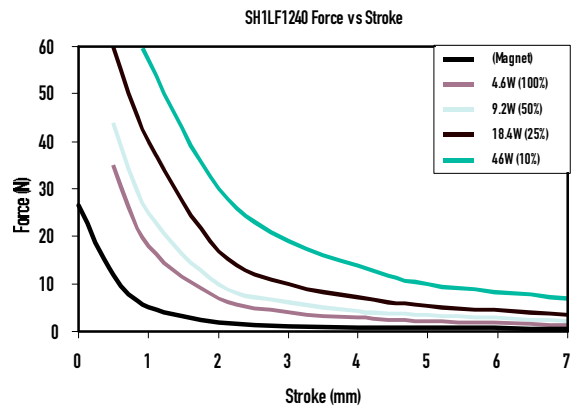
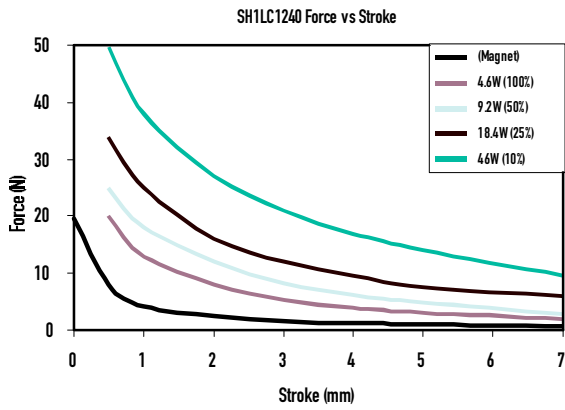

[Latching solenoids]

T1L-0420

Part Number	Duty Cycle		25%	Release Load 0.5N @ Release Current
	Maximum 'ON' time		4	
	Power Consumption (W @ 20°C)		1.6	
	Ampere-Turns @ 20°C			
	Resistance (Ω @ 20°C)	Coil Turns	V DC	
T1L0420-06	36		6	170mA
T1L0420-12	144		12	80mA
T1L0420-24	576		24	40mA

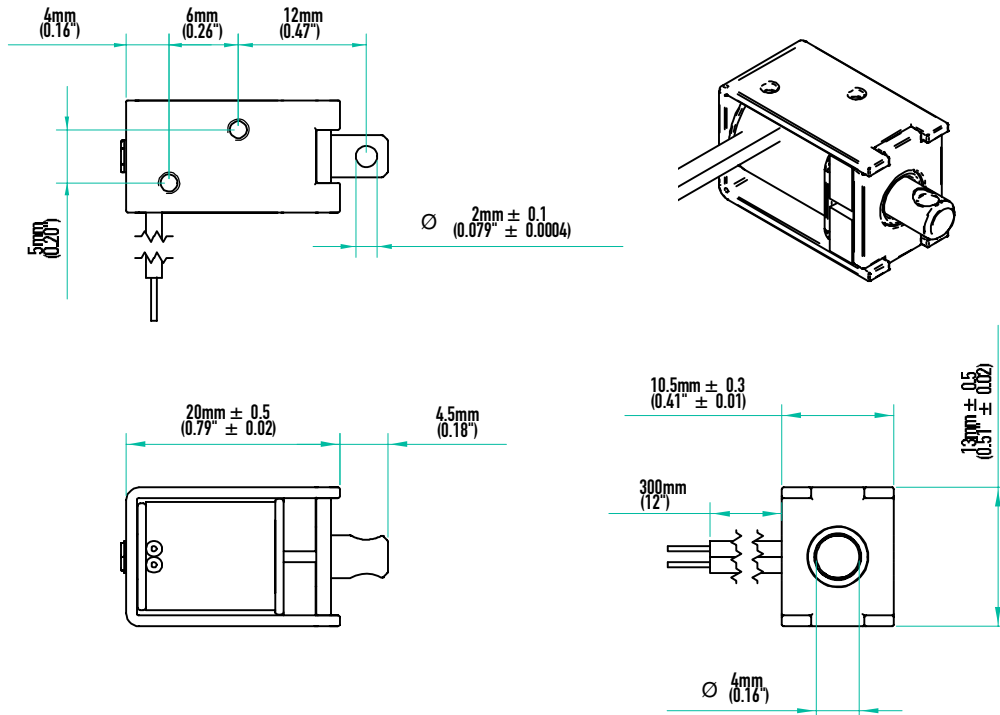
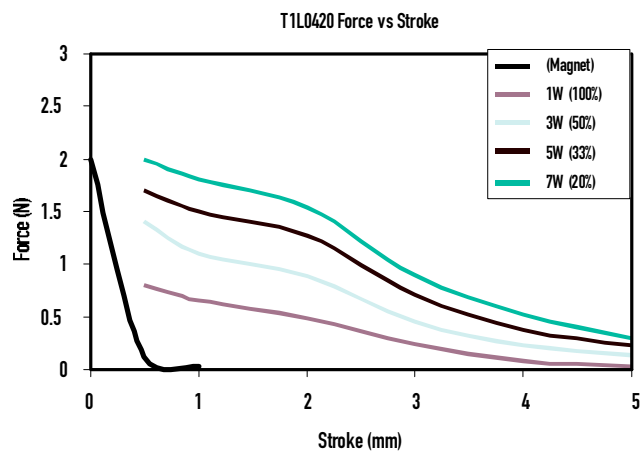

[Latching solenoids]

T1L-0422

Part Number	Duty Cycle		50%	Release Load 0.5N @ Release Current
	Maximum 'ON' time		8	
	Power Consumption (W @ 20°C)		2.8	
	Ampere-Turns @ 20°C			
	Resistance (Ω @ 20°C)	Coil Turns	V DC	
T1L0422-06	36		6	170mA
T1L0422-12	144		12	80mA
T1L0422-24	576		24	40mA

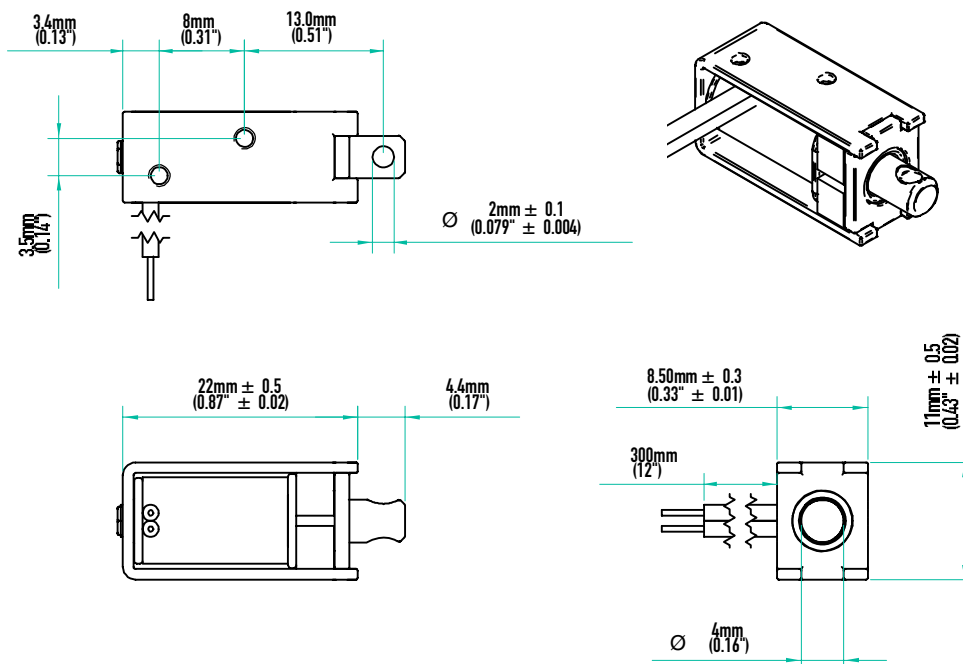
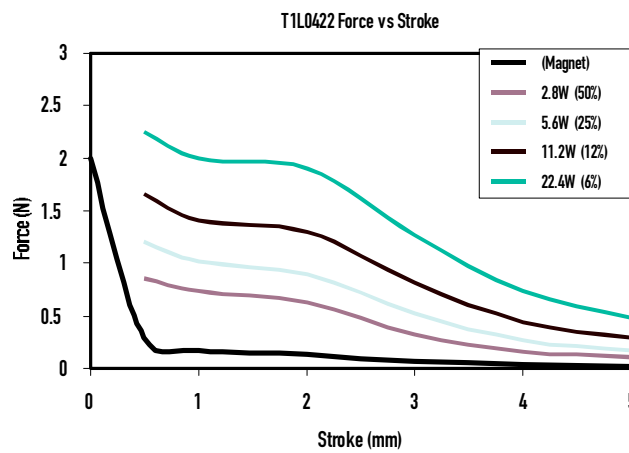

[Latching solenoids]

T1L-0625

Part Number	Duty Cycle		33%	Release Load 1N @ Release Current
	Maximum 'ON' time		10	
	Power Consumption (W @ 20°C)		5.3	
	Ampere-Turns @ 20°C			
	Resistance (Ω @ 20°C)	Coil Turns	V DC	
T1L0625-06	6.8		6	880mA
T1L0625-12	27		12	440mA
T1L0625-24	108		24	220mA

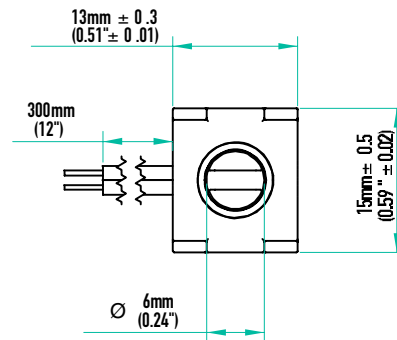
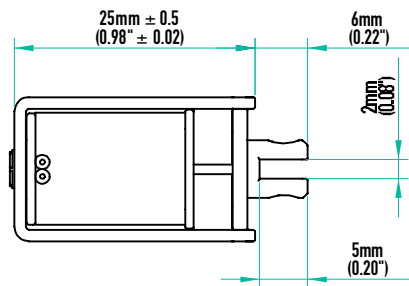
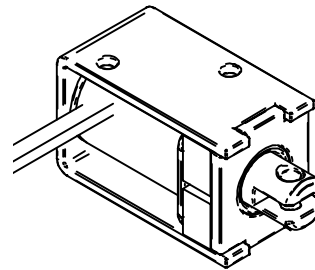
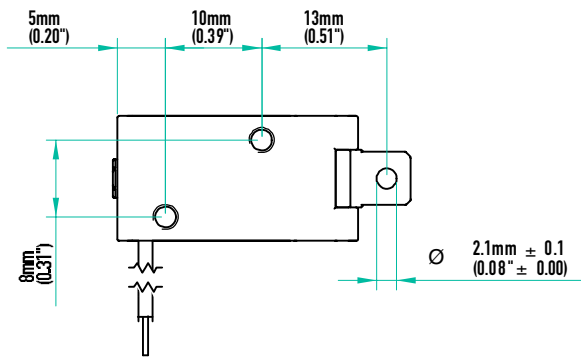
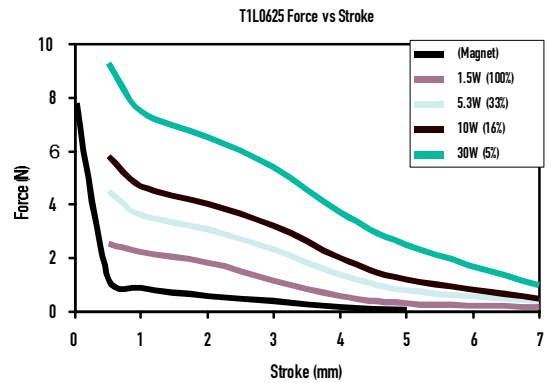

Part Number	Duty Cycle		33%	Release Load 0.5N @ Release Current
	Maximum 'ON' time		?	
	Power Consumption (W @ 20°C)		1.8	
	Ampere-Turns @ 20°C			
	Resistance (Ω @ 20°C)	Coil Turns	V DC	
T1LP0625-06	20		6	300mA
T1LP0625-12	80		12	150mA
T1LP0625-24	320		24	75mA

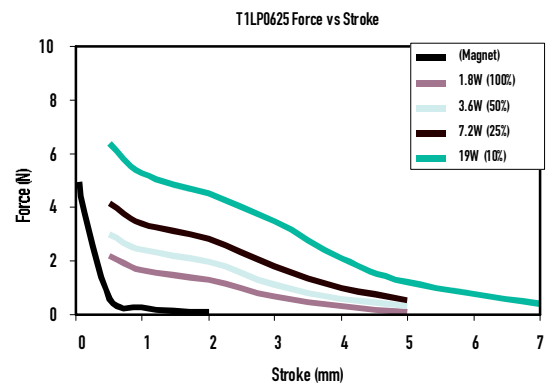

[Latching solenoids]

T1L-0730

Part Number	Duty Cycle		50%	Release Load 0.5N @ Release Current
	Maximum 'ON' time		10	
	Power Consumption (W @ 20°C)		4.8	
	Ampere-Turns @ 20°C			
	Resistance (Ω @ 20°C)	Coil Turns	V DC	
T1L0730-06	7.5		6	800mA
T1L0730-12	30		12	400mA
T1L0730-24	120		24	200mA

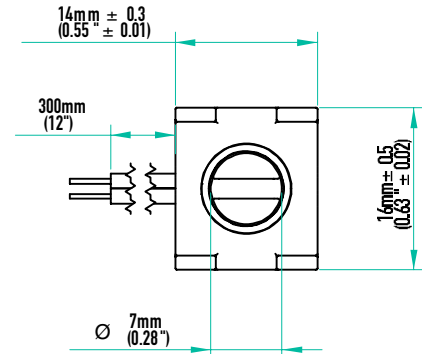
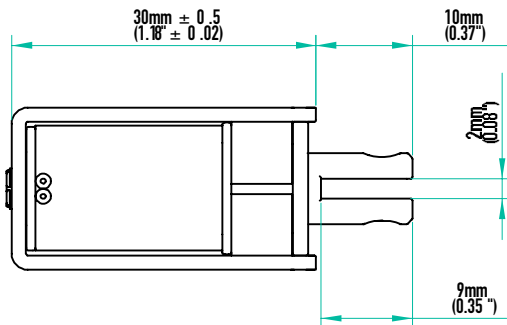
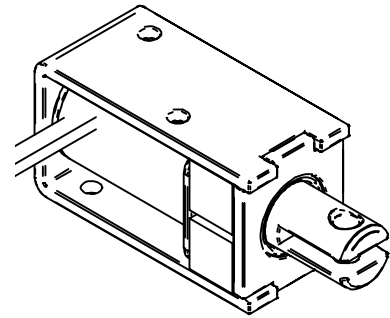
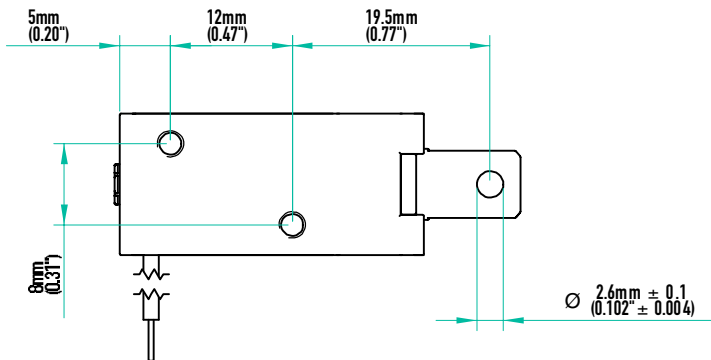
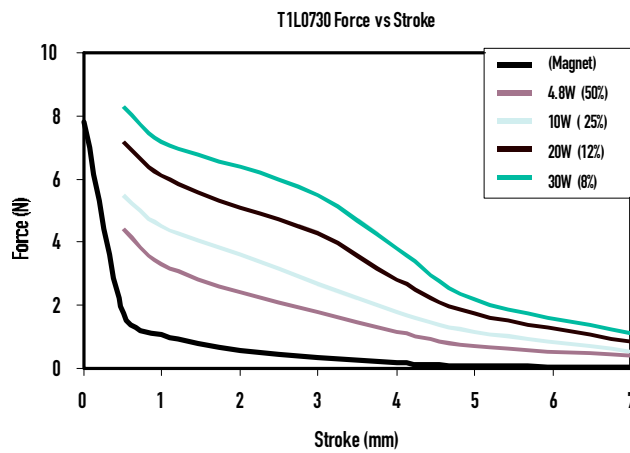

[Latching solenoids]

T1L-0742

Part Number	Duty Cycle		100%	Release Load 1N @ Release Current
	Maximum 'ON' time		?	
	Power Consumption (W @ 20°C)		2	
	Ampere-Turns @ 20°C			
	Resistance (Ω @ 20°C)	Coil Turns	V DC	
T1L0742-06	18		6	333mA
T1L0742-12	72		12	167mA
T1L0742-24	288		24	83mA

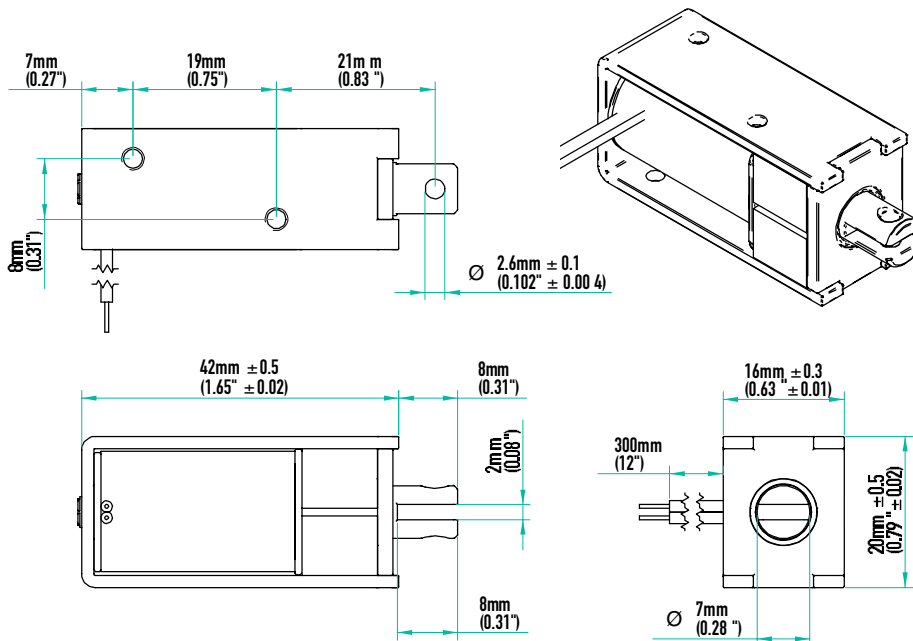
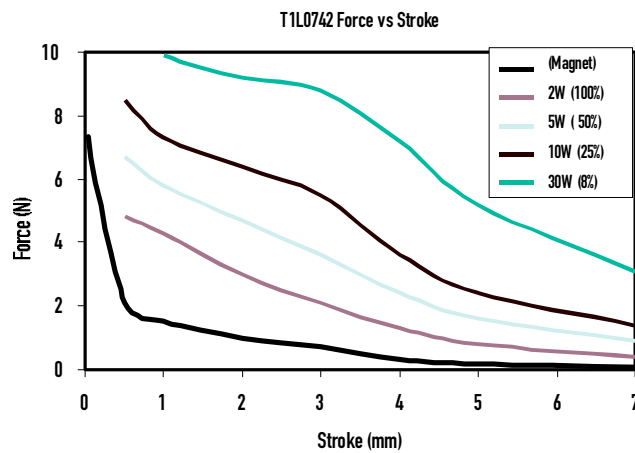

[Latching solenoids]

T1L-1037

Part Number	Duty Cycle		33%	Release Load 0.5N @ Release Current
	Maximum 'ON' time		10	
	Power Consumption (W @ 20°C)		12	
	Ampere-Turns @ 20°C			
	Resistance (Ω @ 20°C)	Coil Turns	V DC	
T1L1037-06	3		6	2000mA
T1L1037-12	12		12	1000mA
T1L1037-24	48		24	500mA

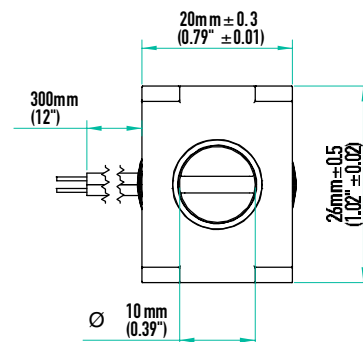
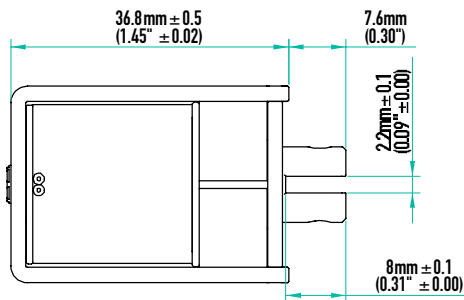
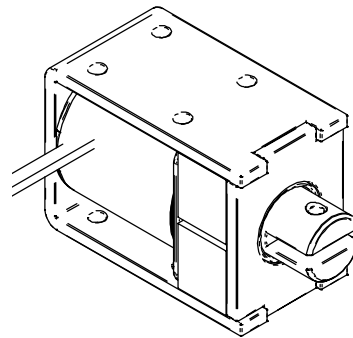
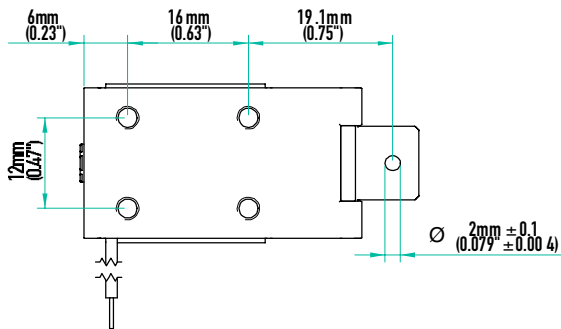
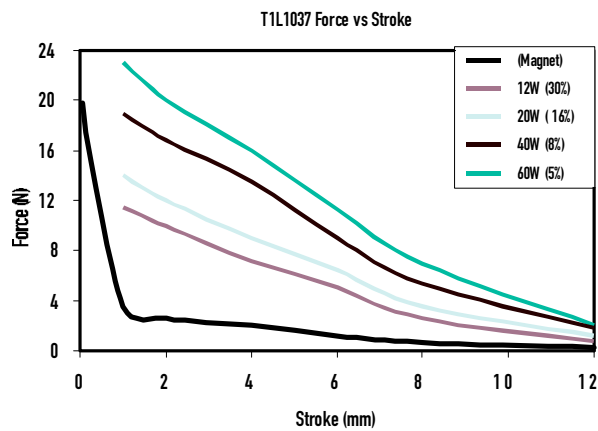

[Latching solenoids]

T1L-1240

Part Number	Duty Cycle		50%	Release Load 1N @ Release Current
	Maximum 'ON' time		?	
	Power Consumption (W @ 20°C)		8	
	Ampere-Turns @ 20°C			
	Resistance (Ω @ 20°C)	Coil Turns	V DC	
T1L 1240-06	4.5		6	1330mA
T1L 1240-12	18		12	670mA
T1L 1240-24	72		24	330mA

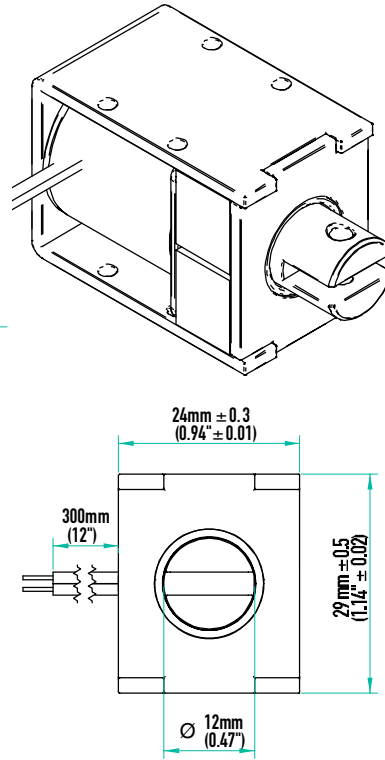
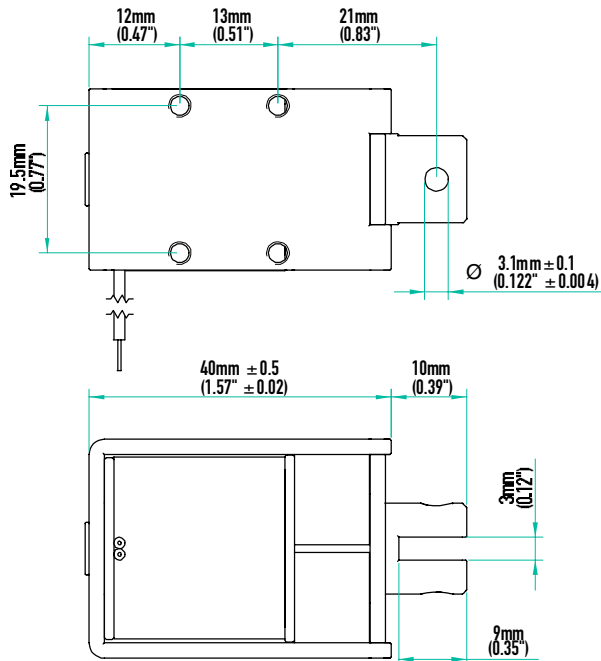
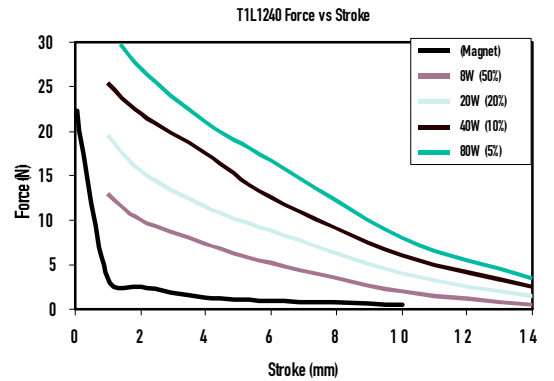

Part Number	Duty Cycle		50%	Release Load 1N @ Release Current
	Maximum 'ON' time		?	
	Power Consumption (W @ 20°C)		8	
	Ampere-Turns @ 20°C			
	Resistance (Ω @ 20°C)	Coil Turns	V DC	
T1LP1240-06	4.5		6	1330mA
T1LP1240-12	18		12	670mA
T1LP1240-24	72		24	330mA

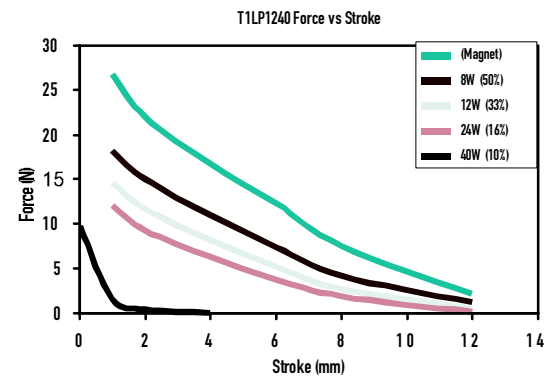

[Latching solenoids]

T1L-1253

Part Number	Duty Cycle		100%	Release Load 0.5N @ Release Current
	Maximum 'ON' time		15	
	Power Consumption (W @ 20°C)		10	
	Ampere-Turns @ 20°C			
	Resistance (Ω @ 20°C)	Coil Turns	V DC	
T1L1253-06	3.6		6	1670mA
T1L1253-12	14.4		12	830mA
T1L1253-24	57.6		24	420mA

