

[Industrial tubular solenoids]

[GIT series solenoids are designed for long life operation in industrial applications. The solenoids use dry bearings for maintenance free operation, life expectancy of the bearing system is typically >50M operating cycles. A special stop-washer design ensures low impact noise at the limits of stroke. The force characteristic of these parts can be modified by changing the shape of the polepiece to give more linear force / displacement distribution, or to give high starting or finishing force optimised to a customer application.]

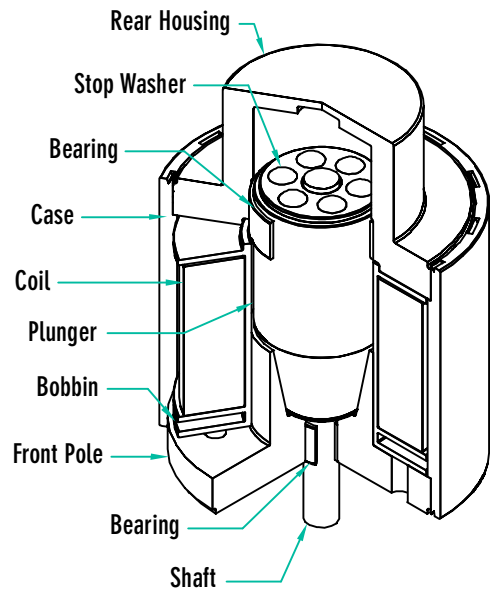

GIT-4470

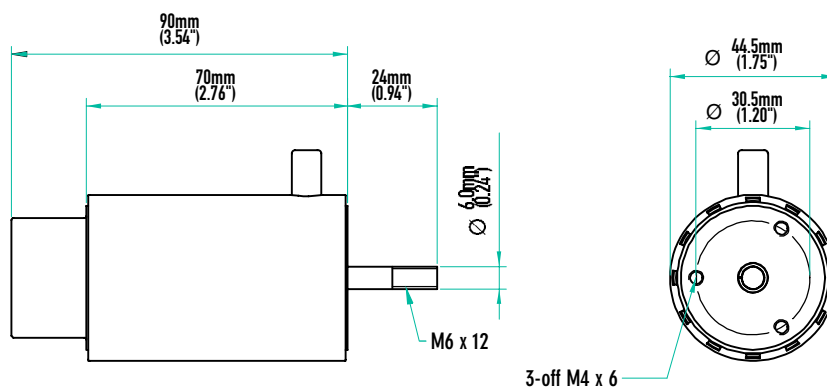
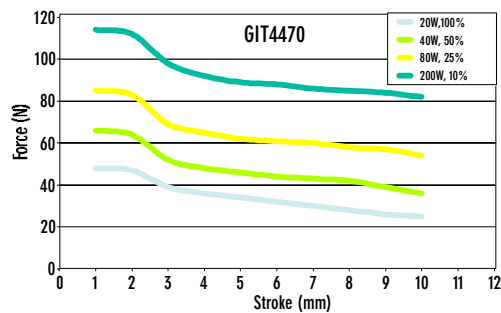

[Industrial tubular solenoids]

GIT-5576

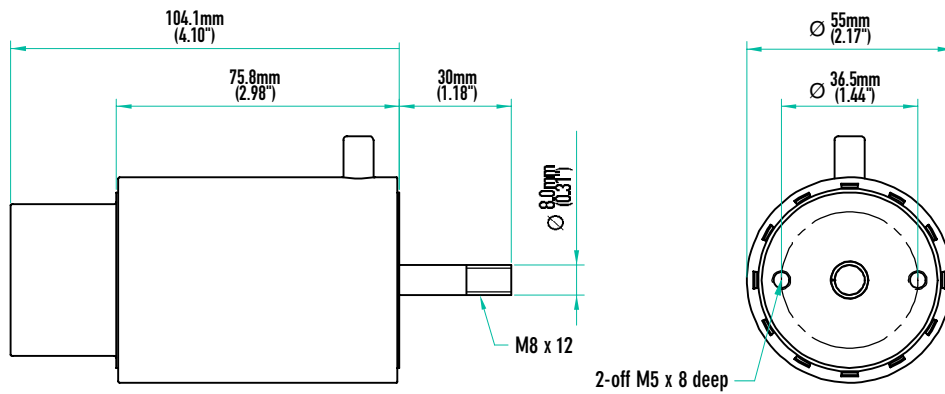
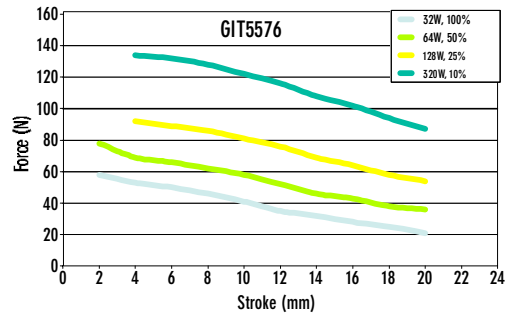

GIT-7468

